

# The Equipment Rules

**R&A**

**USGA**<sup>®</sup>

# The Equipment Rules

By  
The R&A and USGA

Effective December 1, 2024  
(Version 1.3)

This publication contains the comprehensive Rules, specifications and guidelines to assist equipment manufacturers and designers, tournament officials, players and other interested parties in understanding and applying the Rules relating to clubs, balls, devices and other equipment.

An interactive version of The Equipment Rules is accessible from The R&A's or United States Golf Association's (USGA's) website ([www.randa.org](http://www.randa.org) or [www.usga.org](http://www.usga.org)), which includes links to official test protocols and/or video demonstrations relevant to the specific Rule, specification or measurement technique being covered.

The Equipment Rules will continue to be reviewed and modifications may be made from time to time in the future.

The principles and philosophies expressed within this publication are held by both The R&A and the USGA.



# List of Contents

	Page
INTRODUCTION.....	4
<b>THE EQUIPMENT RULES</b>	
Preamble .....	5
<b>PART I – GOLF CLUB PLAYING RULES</b>	
Rule 4 – The Player’s Equipment.....	7
Rule 4.1 – Clubs .....	7
(1) Conforming Clubs .....	7
(2) Use, Repair or Replacement of Club Damaged During Round.....	8
(3) Deliberately Changing Club’s Playing Characteristics During Round.....	9
<b>PART 2 – CONFORMANCE OF CLUBS</b>	
Preamble .....	11
1. Clubs	
a. General .....	11
(i) Traditional and Customary Form and Make.....	12
(ii) Club Composition.....	13
(iii) All Parts must be Fixed .....	13
(iv) External Attachments .....	13
b. Adjustability.....	15
(i) General.....	15
(ii) Adjustability for Weight .....	17
(iii) Adjustability for Length .....	17
(iv) Other Kinds of Adjustability.....	18
c. Length.....	19
d. Alignment.....	21
2. Shaft	
a. Straightness .....	27
b. Bending and Twisting Properties.....	29
c. Attachment to Clubhead.....	30
3. The Grip	
a. Definition .....	32
b. Cross-section.....	33
(i) Circular Cross-section for Woods and Irons.....	33
(ii) Putters.....	34
(iii) Cross-Sectional Dimension.....	35
(iv) Axis of the Grip.....	35
c. Two Grips.....	35

# List of Contents

	Page
4. Clubhead	
a. Plain in Shape .....	37
(i) All Clubs.....	38
(ii) Woods and Irons.....	46
b. Dimensions, Volume and Moment of Inertia .....	48
(i) Woods.....	48
(ii) Irons .....	51
(iii) Putters.....	52
c. Spring Effect and Dynamic Properties.....	53
d. Striking Faces .....	54
5. Club Face	
a. General.....	55
b. Impact Area Roughness and Material.....	55
(i) Definition of “Impact Area” .....	56
(ii) Impact Area Roughness.....	57
(iii) Impact Area Material .....	57
c. Impact Area Markings .....	57
(i) Grooves.....	58
(ii) Punch Marks .....	59
(iii) Groove/Punch Mark Combinations .....	61
d. Decorative Markings .....	62
e. Non-metallic Club Face Markings .....	63
f. Putter Face.....	63
 <b>PART 3 – THE GOLF BALL PLAYING RULES</b>	
Rule 4 - The Player’s Equipment.....	64
Rule 4.2 – Balls .....	64
Balls Allowed in Play of Round .....	64
The List of Conforming Golf Balls.....	64
 <b>PART 4 – CONFORMANCE OF BALLS</b>	
1. General.....	65
2. Weight.....	66
3. Size .....	66
4. Spherical Symmetry.....	66
5. Initial Velocity.....	66
6. Overall Distance Standard .....	67

**PART 5 – EQUIPMENT PLAYING RULES**

Rule 4.3 – Use of Equipment.....	68
----------------------------------	----

**PART 6 – DEVICES AND OTHER EQUIPMENT**

1. Tees (Rule 6.2) .....	69
2. Gloves (Rule 4.3).....	69
3. Shoes (Rule 4.3).....	70
4. Clothing (Rule 4.3).....	70
5. Use of Tape, including Kinesiology Tape (Rule 4.3).....	71
6. Distance Measuring Devices (Rule 4.3).....	71
7. Definition of Alignment Device and Treatment of Ball-Markers (Rule 4.3) .....	71

**PART 7 – MODIFIED EQUIPMENT RULES FOR PLAYERS WITH  
DISABILITIES**

1. Length.....	72
2. Grips.....	72

**PART 8 – COMMITTEE EQUIPMENT REQUIREMENTS**

1. The Flagstick a. The Pole.....	73
b. The Flag and Ornamental Attachments.....	73
c. Other Attachments.....	74

**SUPPLEMENTARY PAPER A**

Advice to Rules Officials Concerning Queries on the Conformity of Clubs at Competitions .....	75
--	----

**SUPPLEMENTARY PAPER B**

Guidance on how to Measure Grooves on Club Faces for Conformance to Pre-2010 Rules in the Field.....	79
---	----

**SUPPLEMENTARY PAPER C**

2010 Club Face Markings.....	92
------------------------------	----

## Introduction

With respect to the equipment which may be used to play the game, The Rules of Golf (“the Rules”) reference the Equipment Rules. In general, the Equipment Rules are “descriptive” and “restrictive” in nature – defining what golf equipment should look like and limiting how it performs.

The main objective of the Equipment Rules is to ensure that technological advances in the design and manufacture of golf equipment are in the best interests of the game of golf. While not wishing to stifle innovation, the purpose of the Equipment Rules is to protect the traditions of the game, to prevent an over-reliance on technological advances rather than on practice and skill, and to preserve skill differentials throughout the game.

It is the role of The R&A’s and USGA’s Equipment Standards Committees to interpret and apply the Equipment Rules relevant to clubs, balls, devices and other equipment and to determine and advise which equipment conforms and which equipment does not. The Committee is also responsible for recommending modifications to the Equipment Rules, if and when changes are believed to be necessary.

In order to achieve consistency in the decision-making process, a database of all previous decisions is kept and maintained. Also, over time, the Committee has developed a comprehensive set of “guidelines” based on these decisions to help interpret the Equipment Rules in a consistent way.

The Equipment Rules incorporate many of these guidelines and interpretations to help equipment manufacturers and designers, tournament officials, players and other interested parties interpret and apply them. The purpose of Supplementary Paper A is to offer advice on the procedure an official should follow when faced with an equipment ruling immediately before or during a competition.

Many of the Rules relating to clubs, balls, devices and other equipment can be technical and complex in nature. However, almost without exception, the Equipment Rules become understandable after only a brief explanation, or with the aid of a simple diagram. Whenever possible, the Equipment Rules will attempt to explain both the background to a provision and the objective behind it. Also, where practical, the Equipment Rules will offer advice as to how best to carry out certain measurements.

Throughout The Equipment Rules there are specific sections which are highlighted by blue shading. These sections are either direct statements of Rule 4 or contain specific requirements for equipment. These are the most important sections of The Equipment Rules and together constitute the specifications against which equipment is evaluated.

## PREAMBLE

A player in doubt as to the conformity of equipment used to play the game should consult The R&A or USGA. A manufacturer should submit to The R&A or USGA a sample of the equipment to be manufactured for a ruling as to whether it conforms with the Equipment Rules. The sample becomes the property of The R&A or USGA for reference purposes. If a manufacturer fails to submit a sample, or, having submitted a sample, fails to await a ruling before manufacturing and/or marketing the equipment, the manufacturer assumes the risk of a ruling that the equipment does not conform to the Equipment Rules.

Where a club, ball, device, other equipment, or part thereof, is required to meet a specification within the Equipment Rules, it must be designed and manufactured with the intention of meeting that specification.

This point can be illustrated using Part 2, Section 2a, which states, in part, that “The shaft must be straight”. According to the above clause, this means that manufacturers are expected to design shafts with the intention that they will be straight. However, taking into consideration the materials commonly used to make shafts and the manufacturing techniques involved, it is not always possible for them to be perfectly straight. As long as it is clear that the shaft is designed and manufactured with the intention of being straight, a reasonable level of tolerance is given when evaluating shafts for conformance.

The R&A and USGA reserve the right, at any time, to change the rules relating to clubs, balls, devices and other equipment and make or change the interpretations relating to these Equipment Rules. For up to date information, please contact The R&A or USGA, or refer to our respective websites. Any design of a club, ball, device or other equipment that is not covered by the Equipment Rules, which is contrary to the purpose and intent of the Rules or that might significantly change the nature of the game, will be ruled on by The R&A and USGA.

The dimensions and limits contained in the Equipment Rules are given in the units by which conformance is determined. An equivalent imperial/metric conversion is also referenced for information, calculated using a conversion rate of 1 inch = 25.4 mm and 1 oz = 28.35g.



The vast majority of people who play golf assume that when they buy items of golf equipment, they conform with the Equipment Rules. To help prevent non-conforming equipment from appearing in the marketplace or from being used, The R&A and USGA offer an equipment testing and evaluation service to manufacturers, and encourage manufacturers to submit drawings, descriptions, and/or prototype samples of new product to the appropriate governing body as early in the development process as possible, prior to mass production and distribution, in order to avoid potentially costly consequences should The R&A or USGA determine that the product does not conform. Additionally, this process helps to protect golfers from unwittingly obtaining non-conforming equipment for use under the Rules of Golf. While this procedure works most of the time, there are occasions when non-conforming equipment is sold in the marketplace. That, combined with the fact that many golfers like to make their own modifications to clubs (see Rule 4-1a. Clubs Allowed in Making a Stroke), make the Equipment Rules an important tool for all concerned.

## PART I – GOLF CLUB PLAYING RULES

### Rule 4 – The Player’s Equipment

**Purpose:** Rule 4 covers the equipment that players may use during a round. Based on the principle that golf is a challenging game in which success should depend on the player’s judgment, skills and abilities, the player:

- Must use conforming clubs and balls,
- Is limited to no more than 14 clubs and normally must not replace damaged or lost clubs, and
- Is restricted in the use of other equipment that gives artificial help to his or her play.

#### Rule 4.1 Clubs

##### a. Clubs Allowed in Making a Stroke

(1) **Conforming Clubs.** In making a stroke, a player must use a club that conforms to the requirements in the Equipment Rules when:

- It is new, or
- Its playing characteristics have been changed in any way (but see Rule 4.1a(2) when a club is damaged during the round)

**But** if the playing characteristics of a conforming club change because of wear through normal use, it is still a conforming club.

The “playing characteristics” of a club are any part, feature or property that affects how the club performs or aids in alignment, including but not limited to, weighting, lie, loft, alignment features and permissible attachments.

#### Player’s Responsibility

It is the player’s own responsibility to ensure that his or her clubs conform to the Equipment Rules. If the player has any doubt as to the conformity of a club, he or she should consult The R&A or USGA. Queries may also be directed to the local committee in charge of a competition or the local Rules Committee.

## Wear

Over time, the face and grip of a club, in particular, may become worn through normal use. For example, a grip may become so worn that it becomes moulded for the hands, or the grooves on an iron club may become so worn that they no longer conform to the requirements in Part 2, Section 5c of the Equipment Rules.

A club that conforms with the Equipment Rules when new is still a conforming club because of wear through normal use. In essence, a club which conformed when new cannot be rendered non-conforming due to its wear through normal use. However, a club which did not conform to the Equipment Rules when new cannot be worn, through normal use, to a conforming state. Such a club would always be considered non-conforming. In general, “wear” is defined to be the erosion of material (as opposed to “damage”, which is usually caused by a single load or repeatedly applied loads). Material decomposition or deterioration is not generally considered to be wear.

When a used club is pendulum tested (see Part 2 Section 4c(i)) in the field and a result in excess of 257  $\mu$ s is attained, the specific club will be deemed to be damaged into a non-conforming state, based on the presumption that it conformed when new and was included on the List of Conforming Driver Heads. As such, any individual club tested in excess of 257  $\mu$ s will not be permitted to be used in play during any subsequent stipulated round since it does not conform to the Rules of Golf. The damage will be deemed to have occurred after the start of the previous stipulated round (i.e., prior to the field test), so that no retrospective penalties would be applied, unless the player had knowledge, prior to the field test, that the club did not conform.

Rule 4.1a continues

(2) Use, Repair or Replacement of Club Damaged During Round. If a conforming club is damaged during a round or while play is stopped under Rule 5.7a, except in cases of abuse, the player may repair it or replace it with another club.

**But** no matter what the nature or cause of the damage, the damaged club is treated as conforming for the rest of the round (but not during a play-off in stroke play, which is a new round).

For the rest of the round, the player may:

- Continue to make strokes with the damaged club, or
- Except in cases of abuse, repair the club or replace it with another club (see Rule 4.1b(4)).

If the player replaces the damaged club with another club, the player must take the damaged club out of play before making another stroke using the procedure in Rule 4.1c(1).

“Damaged during a round” means when any part, feature or property of a club is changed because of any act during the round (including while play is stopped under Rule 5.7a), whether:

- By the player (such as making a stroke or practice swing with the club, putting it in or taking it out of a golf bag, dropping or leaning on it, or throwing or abusing it), or
- By any other person, outside influence or natural forces.

But a club is not “damaged during a round” if its playing characteristics are deliberately changed by the player during the round, as covered by Rule 4.1a(3).

(3) Deliberately Changing Club’s Playing Characteristics During Round. A player must not make a stroke with a club when they have deliberately changed that club’s playing characteristics during the round (including while play is stopped under Rule 5.7a):

- By using an adjustable feature or physically changing the club (except when allowed to repair damage under Rule 4.1a(2)), or
- By applying any substance to the clubhead (other than in cleaning it) to affect how it performs in making a stroke.

Exception – Adjustable Club Restored to Original Position or Non-Permissible External Attachment Removed: There is no penalty and the club may be used to make a stroke in the following two situations:

- If a club’s playing characteristics were changed by using an adjustable feature and, before the club is used to make a stroke, the club is restored as nearly as possible to its original position by adjusting the feature back to where it was.
- A non-permissible external attachment (such as a sticker on the club face) is removed from the club before the club is used to make a stroke.

## **Playing Characteristics Deliberately Changed**

The purpose of this Rule is to penalize a player that purposely modifies his or her club during a round – for example to a flatter lie, a greater loft, an alternative weight distribution or changing the head or shaft, regardless of whether the club has been designed to be adjustable.

Additionally, this Rule penalizes a player that applies materials of a temporary nature to the face – such as saliva, grass juice, chalk, aerosol spray or similar substances. Permanent attachments or coatings such as plasma spray, “balata”-type rubber or paint are covered under Part 2, Section 5 of the Equipment Rules.

The most important question to ask when ruling on a club which has had something temporarily applied to the face by a player is “why has it been put there?” If a material or substance has been applied to the face in order to protect it or clean it, then it would probably be permitted provided all other Rules are satisfied. However, if the purpose of the application is to influence the movement of the ball or assist the player in making a stroke, it would be prohibited.

Any type of tape or similar material added to the face is not permitted for any purpose.

## PART 2 – CONFORMANCE OF CLUBS

The rules and specifications regarding golf clubs are divided into five separate categories, describing the requirements that apply to each. The five categories are:

1. Club (General)
2. Shaft
3. Grip
4. Clubhead
5. Club Face

### I. Clubs

#### a. General

A club is an implement designed to be used for striking the ball and generally comes in three forms: woods, irons and putters distinguished by shape and intended use. A putter is a club with a loft not exceeding ten degrees designed primarily for use on the putting green.

The terms “wood” and “iron” refer to the general shape of the clubhead. A wood club is one where the head is relatively broad from face to back, and it can be made of a variety of materials. An iron club is one where the head is relatively narrow from face to back, and it is usually made of steel. While it can be challenging to distinguish between these two club types because of the popularity of “hybrid”, rescue and utility clubs, the determination of whether a club is a “wood” or an “iron” and, in turn, which Equipment Rules apply to it is dealt with based on an overall assessment of the shape and size of the head.

By definition, the loft of a putter must not be greater than 10 degrees. Putters are permitted to have negative loft. However, a negative loft exceeding a magnitude of 15 degrees would not be considered “traditional and customary in form and make” (see Section 1a(i) below).

The Equipment Rules rarely distinguish between wood and iron clubs (see Section 4b, Dimensions, Volume and Moment of Inertia, for the main example of different treatment), but there are various instances throughout the Equipment Rules where certain specifications do not apply to putters or exceptions may be made for putters. These differences will be highlighted at the appropriate places throughout the Equipment Rules.

Probably as a consequence of these differences, confusion often exists as to which Equipment Rules apply to “chippers”. A “chipper” is an iron club designed primarily for use off the putting green, generally with a loft greater than ten degrees. As most players adopt a “putting stroke” when using a chipper, there can be a tendency to design the club as if it was a putter. To eliminate confusion, the Equipment Rules which apply to chippers include:

1. The shaft must be attached to the clubhead at the heel (Section 2c);
2. The grip must be circular in cross-section (Section 3b(i)) and only one grip is permitted (Section 3c);
3. The clubhead must be generally plain in shape (Section 4a) and have only one striking face (Section 4d); and,
4. The face of the club must conform to the specifications with respect to hardness, surface roughness, material, markings in the impact area and dynamic properties (Sections 4c and 5).
5. The length of the club must follow the guidelines for chippers specified in the table located in Section 1c.

The club must not be substantially different from the traditional and customary form and make. The club must be composed of a shaft and a head and it may also have material added to the shaft to enable the player to obtain a firm hold (see Section 3 below). All parts of the club must be fixed so that the club is one unit, and it must have no external attachments. Exceptions may be made for attachments that do not affect the performance of the club.

In explaining this provision, it is easier to break it down into the following four sections:

#### **(i) Traditional and Customary Form and Make**

The phrase “traditional and customary form and make” does not mean that clubs must look the same as they did 100 years ago. If so, for example, steel shafts and metal-headed woods would not conform.

The “traditional and customary” clause is used when there is not a specific provision that can be applied to a specific, non-traditional club feature, and/or the overall club design deviates from traditional appearance and/or construction standards. For clubheads, the “Plain in Shape” provision generally applies (see Section 4a, below).

**(ii) Club Composition**

This clause means that a club is not permitted to have multiple shafts or heads. It also highlights that it is not essential for a club to have material added to the shaft to form a grip. For further information on a club which has no material added to form a grip, see Section 3.

**(iii) All Parts must be Fixed**

This clause means that no part of the golf club should be designed to move, nor should it be promoted as doing so. Once assembled, all parts of the club which are bonded must be bonded such that they require heat to loosen (see Section 1b below for clubs which are designed to be adjustable). If any part of a club were to incorporate moving powder, pellets, liquid, vibrating wires, rollers, tuning forks, or any number of other features which could be considered a “moving part”, the club would not conform.

**(iv) External Attachments**

While this clause prohibits the attachment of anything to the club which could potentially have an effect on its performance (e.g. aiming bars or weights), other items may be permitted to be attached to certain parts of the club provided (a) no performance benefit can be derived, and (b) no other Equipment Rules are breached, as well as Rule 4.3 of the Rules of Golf (Use of Equipment).

Examples of attachments that could be permitted include:

- Temporary, non-permanent attachments to the shaft such as decals for identification - such attachments, for identification only, may also be permitted on the clubhead (other than the face). Additionally, tape to protect the shaft is permitted. However, these attachments must not be usable for any other purpose (e.g. alignment).
- Temporary, non-permanent attachments to the shaft (e.g. “clip-on” devices), provided such items do not excessively protrude from the shaft, their cross-section conforms to the shape of the shaft and they are sufficiently fixed. Other “clip-on” devices that do not conform to the shape of the shaft (e.g. a club “prop” for use in wet weather) may be attached to the shaft between shots but must be removed prior to making a stroke.



- Other material added to the shaft, such as for alignment purposes, provided it is considered semi-permanent. However, such applications must not breach Rule 4.3. “Semi-permanent” is interpreted to mean durable and not easily removable. Additionally, it must not be re-usable and/or must be essentially destroyed upon removal.
- Temporary, non-permanent attachments to the butt end of the grip such as tee pegs, ball markers or ball retrieving devices, provided:
  - such items do not cause the grip to be considered moulded for the hands or create a bulge or waist in the grip; and
  - the outer diameter of the item is less than or equal to the outer diameter of the butt end of the grip and the item does not extend beyond the butt end of the grip by more than 2 inches (50.8mm).
- Other temporary, non-permanent attachments to any part of the grip other than the butt end, provided such items are removed prior to making a stroke. However, tape or gauze applied to the full length of the grip is permitted provided the grip conforms in its modified state and the underlying grip conforms.
- Attachments to the clubhead (other than the face), such as protective coverings, decorative items or alignment aids, provided the item is semi-permanent. However, such items must not excessively protrude from the clubhead and must conform to the shape of the clubhead. Also, for driving clubs, such attachments must not serve to cause any confusion with the correct identification of a club on the List of Conforming Driver Heads. Such attachments should, therefore, be subtle, plain in appearance and discreetly positioned. Permanent additions to a clubhead would be considered part of the head and, therefore, the head, in its modified state, would have to conform to Part 2, Section 4 of the Equipment Rules (i.e. for dimensions and “plain in shape”).

The two long-standing permissible “external attachments” are (a) the permission to use lead tape on the shaft or the head for weighting, and (b) the use of a suction cup at the end of the grip of a putter to assist with retrieving the ball from the hole. While lead tape can affect the performance of the club and a rubber suction cup would exceed the diameter of the butt end of the grip, the use of both of these items continue to be permitted on a traditional basis (but see Section 4b(i) below for details on the use of lead tape on driver heads with a high Moment of Inertia).

## b. Adjustability

All clubs may incorporate features for weight adjustment. Other forms of adjustability may also be permitted upon evaluation by The R&A or USGA. The following requirements apply to all permissible methods of adjustment:

- (i) the adjustment cannot be readily made;
- (ii) all adjustable parts are firmly fixed and there is no reasonable likelihood of them working loose during a round; and
- (iii) all configurations of adjustment conform with the Rules.

During a round, a player must not make a stroke with a club when they have deliberately changed that club's playing characteristics by adjustment or by any other means (see Rule 4.1a(3) of the Rules of Golf).

### (i) General

All clubs may be designed to be adjustable for many different characteristics – for example, weight, length, lie and loft. In order to preserve the integrity of Rule 4.1a(3) of the Rules of Golf (“Deliberately” Changing Club’s Performance Characteristics During Round), the Equipment Rules clearly state that it must not be too easy for a player to make adjustments during a round and that the mechanism must be firmly fixed, with little chance of it working loose. All adjustment mechanisms must comply with the following requirements:

#### • Method of Adjustment

Adjustments must require the use of a special tool, such as an Allen key, a Phillips screwdriver or a custom made device. It must not be possible to make the adjustment just by using the fingers or some other object which would normally be kept in a golfer’s pocket, for example a coin or a pitch-mark repair tool.

#### • Unusable Unless Locked or Fully Tightened

If, as is often the case, a screw is used to fix the mechanism, the club must, for all practicable purposes, be unusable without the screw being in place and tightly fixed. One exception to this “unusable” requirement is for a long putter with a shaft which dismantles into two shorter lengths for travel purposes. Here, a screw together (“pool cue”) joint is permitted, in combination with an Allen key screw, or similar, which penetrates the threaded section of the joint by at least half way. The existence of both the threaded joint and the fixing screw potentially renders the putter usable, even when the screw is not tightened, or it is left out entirely. It also renders the putter potentially adjustable by hand. However, this exception was introduced as a specific concession for travel clubs.

### • Friction Fit Mechanisms

Generally, friction fit adjustment mechanisms are not permitted because there is potential for them to be readily adjustable (i.e. the mechanism could be sufficiently tightened such that the club is usable, but not quite enough to prohibit it from being adjustable by hand). However, a friction fit mechanism which can be only locked and unlocked and is fixed in its locked state and unusable in its unlocked state, may be permitted upon evaluation.

### • Discrete Steps

A mechanism that allows for an adjustment to be made in discrete steps may be permitted provided all other Equipment Rules and specifications are satisfied. Without the adjustment mechanism locked in place, the club must essentially be unusable.

The above restrictions have been included in the Equipment Rules in order to encourage the player to make all of the necessary adjustments to his or her clubs before starting the round, and to protect the player from either unwittingly or purposely making adjustments during a round.

When assessing the conformity of an adjustable club, it is important to remember the third condition listed in Part 2, Section 1b, and to check that it cannot be adjusted into a position which does not conform to the Equipment Rules. For example, a putter which is adjustable for lie must not be capable of being adjusted into a position where the shaft diverges from the vertical by less than 10 degrees (see Section 1d, below), or any other position which would render the club non-conforming (see Figure 1).

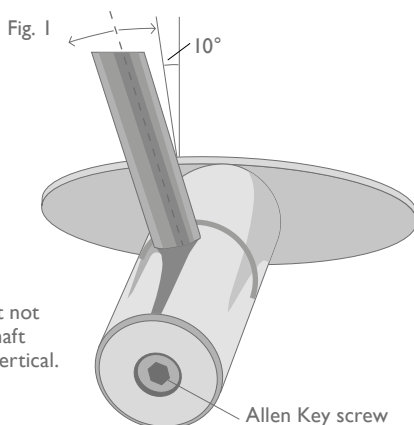

This putter is adjustable for lie – but must not be adjustable into a position where the shaft measures less than 10 degrees from the vertical.

Fig. 2 – Adjustability for weight

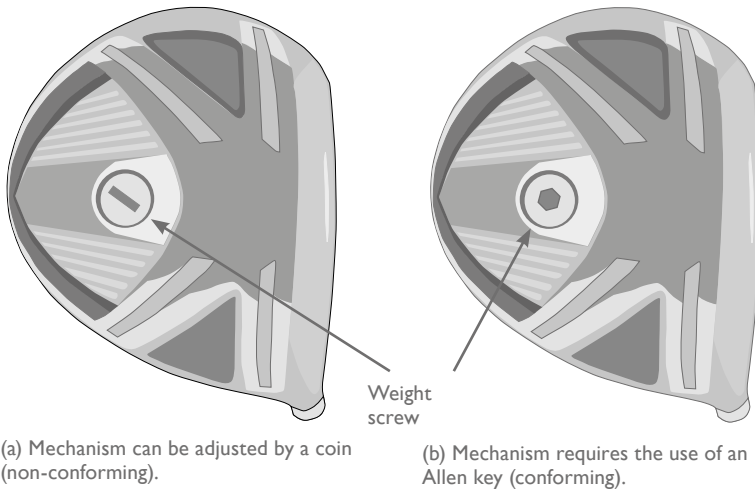

## (ii) Adjustability for Weight

All clubs may be designed to be adjustable for weight, provided the adjustment mechanism conforms to the conditions described in Section 1b of the Equipment Rules. Examples of what would and would not be permitted are illustrated in Figure 2.

As noted in Section 1a, with respect to adjustments for weight, the only exception to the conditions described in Section 1b(i) above is the addition or removal of lead tape. This is a practice which pre-dates the introduction of the adjustability rules and is permitted on 'traditional' grounds. The addition, removal or alteration of lead tape during a round is not permitted (see Rule 4.1a(3) of the Rules of Golf).

## (iii) Adjustability for Length

### • All Clubs

All clubs may be adjustable for length, provided the adjustment mechanism conforms to the specifications already described and is consistent with other Equipment Rules.

Integrated mechanisms are permitted, provided the bending and twisting properties of the shaft remain substantially the same and the grip remains conforming. Mechanisms externally attached to the grip are not permitted.

Telescopic Mechanisms that can be fully extended into a locked position for use and collapsed for travel purposes may be permitted. However, the club must not be usable in its collapsed, unlocked state.

- **Putters**

Non-integrated mechanisms attached to the shaft may be permitted for putters only, provided that:

- The mechanism is generally circular in cross-section with a maximum cross-sectional dimension of 1 inch and a maximum length of 2 inches;
- If the mechanism is situated between two grips, both grips are non-tapered, the end of the mechanism effectively touches the butt end of the lower grip, the cross-sectional dimension of the mechanism is less than or equal to the maximum cross-sectional dimension of the grips, and the mechanism is at least 1.5 inches in length;
- If the mechanism is situated below a single grip or below the lower grip of a putter with two grips, the top of the mechanism is at least 2 inches from the tip end of the grip. Exception: If the size and shape of the mechanism is consistent with the tip end of the grip or the outer diameter of the mechanism is less than the outer diameter of the grip, the mechanism can effectively touch the tip end of the grip.

#### **(iv) Other Kinds of Adjustability**

As previously noted, the adjustability provisions allow all clubs to be designed to be adjustable for many different characteristics – provided all specifications are satisfied. Manufacturers are encouraged, however, to submit all new adjustable design innovations for evaluation in the early stages of development.

Fig. 3

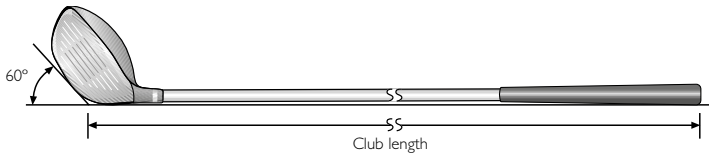

### c. Length

The overall length of the club must be at least 18 inches (0.457m) and, except for putters, must not exceed 48 inches (1.219m).

For woods and irons, the measurement of length is taken when the club is lying on a horizontal plane and the sole is set against a 60 degree plane as shown in Fig. 3. The length is defined as the distance from the point of the intersection between the two planes to the top of the grip. For putters, the measurement of length is taken from the top of the grip along the axis of the shaft or a straight line extension of it to the sole of the club.

This provision is straightforward and the measurement of woods and irons is well described and illustrated above and in the the official test protocol. The measurement of length for putters is illustrated in Figure 4.

Fig. 4

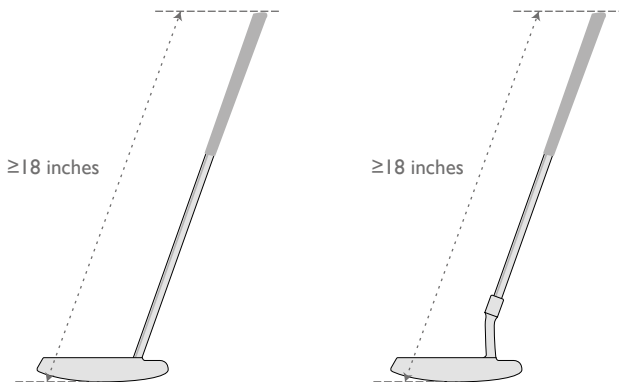

(a) This putter has a straight shaft attached to the clubhead. The measurement for club length follows the axis of the shaft and extends all the way down to the sole.

(b) The shaft of this putter is attached to the head via a neck. The measurement for club length does not follow the axis of the bend in the neck, but follows a straight line extension of the straight part of the shaft all the way to the sole.

Local Committees may permit the use of clubs longer than the maximum length allowed, provided that there is evidence of a medical or physical need for the player to use such clubs and that the shortest club carried by the player is no more than 10 inches shorter than his or her longest club, not including the putter.

The above provisions on club length mean that the concept of long and mid-length putters still conform to the Equipment Rules. However, The R&A and USGA have adopted a position that clubs designed for chipping, including modified wedges, that are longer than standard length clubs of similar loft are not traditional and customary in form and make (see Part 2, Section 1a).

The following table is used for the purpose of determining the maximum allowable length of a chipping club.

Loft Range (°)									
Minimum Loft	16	20	23	26	29	33	37	41	45
Maximum Loft	19	22	25	28	32	36	40	44	48
Maximum Allowable Length (in)	41.5	41	40.5	40	39.5	39	38.5	38	37.5
Maximum Allowable Length (m)	1.054	1.041	1.029	1.016	1.003	0.991	0.978	0.965	0.953

## d. Alignment

When the club is in its normal address position the shaft must be so aligned that:

(i) the projection of the straight part of the shaft on to the vertical plane through the toe and heel must diverge from the vertical by at least 10 degrees (see Fig. 5). If the overall design of the club is such that the player can effectively use the club in a vertical or close-to-vertical position, the shaft may be required to diverge from the vertical in this plane by as much as 25 degrees;

(ii) the projection of the straight part of the shaft on to the vertical plane along the intended line of play must not diverge from the vertical by more than 20 degrees forwards or 10 degrees backwards (see Fig. 6).

Fig. 5

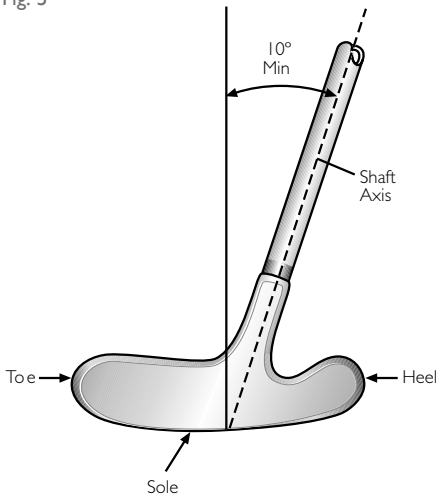
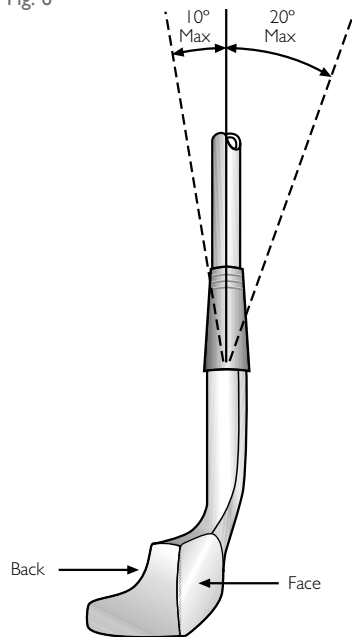

Fig. 6



This provision is particularly relevant to putters and it exists mainly as a means for disallowing croquet style putters (with vertical shafts) and shuffle-board style strokes (see Figure 7). It also seeks to limit the potential for more standard putters from being used effectively in a vertical or near-vertical position using a pendulum-style motion.



Fig. 7

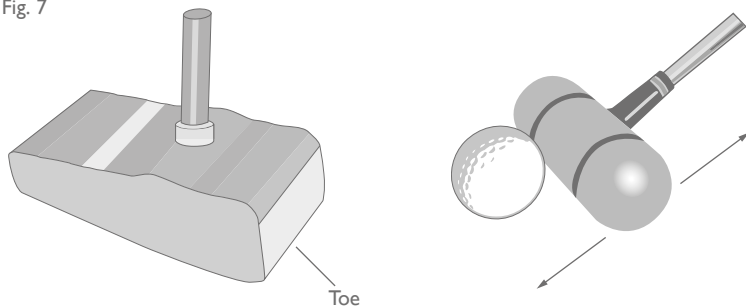

(a) This putter has a vertical shaft and a flat toe – ideal for croquet-style strokes (non-conforming).

(b) This 'shuffle-board' type putter has a cylindrical shaped head that can slide easily across the ground. The player stands behind the ball, facing the hole and "pushes". The shaft diverges from the vertical by more than  $10^\circ$  in the backwards plane (non-conforming).

For most putters, the "normal address position" is determined by the geometry of the head. The head would be placed on a horizontal flat surface, with the sole touching that surface at a point directly below the centre of the face. The shaft angle would then be measured with the head in this position (see Figure 8).

Fig. 8 – Measuring the angle of a putter shaft

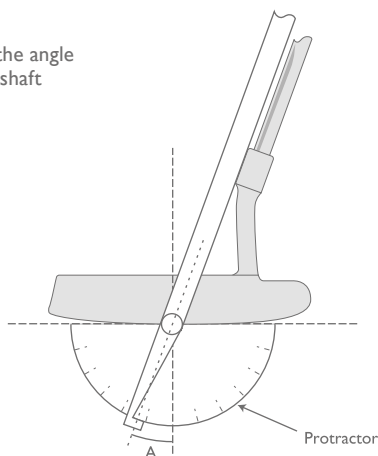

For this putter to conform, angle A must measure at least  $10^\circ$ .

Fig. 9 – Club with asymmetric sole

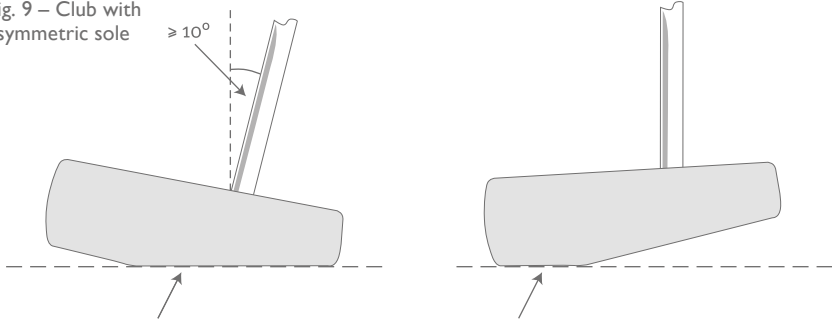

When the putter head is soled in this position, the shaft does diverge from the vertical by at least  $10^\circ$ .

However, when the same putter head is soled in this position, the shaft is vertical. Therefore, putter is non-conforming.

If the putter head shape or weight distribution is very asymmetric, it may be necessary to make a subjective judgement as to where the effective centre of the face is and then to sole the club directly below that point. The position of the head in this instance might not always be the position that was intended when the club was designed, but in some cases a judgement has to be made based on how the club could feasibly and effectively be used (see Figure 9).

The same subjectivity may also be needed when confronted with a putter which has a very curved sole (see Figure 10). As before, the conformance evaluation would take into account not only the manner in which the putter is designed to be used, but also the way it could feasibly and effectively be used, given the geometry of the head as well as other unique characteristics of the overall design. This interpretation is particularly relevant to long-shafted putters with very curved or multi-planed soles – but standard length putters of 34-38 inches can also be subjected to this assessment.

Fig. 10 – Putter with very curved sole

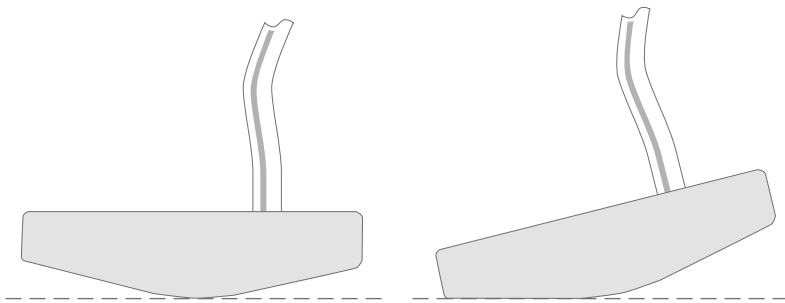

When the putter head is soled in this position, the shaft angle is greater than  $10^\circ$ .

However, when the same putter head is grounded in this position, the shaft angle is less than  $10^\circ$ . Therefore, putter is non-conforming.

It should be noted that all putters can usually be positioned in such a way that the shaft diverges from the vertical by less than  $10^\circ$  or even to a position where the shaft itself is vertical. Also, it is unusual for the sole of a putter to be completely flat all the way from heel to toe. When faced with a ruling of this kind, the decision should not be based on whether a player uses the putter with the shaft in a position less than  $10^\circ$  – but whether the putter design facilitates this (see Figure 11).

Fig. 11 – Putter with curved sole

(a) The sole of this putter is not considered to be 'very curved'. Therefore, the normal address position is deemed to be in the centre of the face.

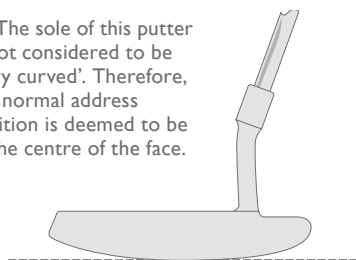

(b) While the angle of the shaft from the vertical is less than  $10^\circ$  in this position, it is not considered to be a feasible address position. Therefore, the putter is conforming and, hence, the player can use it in this position.

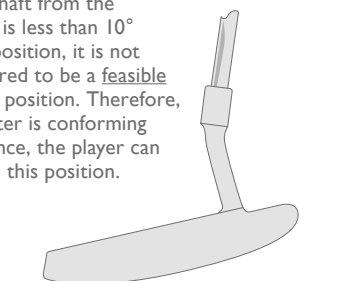

If the overall design of a putter is such that a player can putt effectively with the shaft in a vertical or near-vertical position, it would be ruled contrary to Part 2, Section 1d, even if the shaft angle does satisfy the 10 degree Rule when the putter is in its "normal address position". The shaft angle on such a putter would be required to be increased up to as much as 25 degrees. In assessing whether a putter can be used effectively in such a position and in order to determine what the shaft angle should be increased to, the combination of all of the following features must be considered:

- length of shaft;
- position of shaft attachment to head;
- angle of shaft in toe to heel plane and front to back plane;
- shape and weight distribution of head;
- curvature and shape of sole; and
- intent of the design.

This means that a long putter which has the shaft attached to the toe, a 10 degree lie angle in the toe to heel plane and a curved sole could potentially be ruled non-conforming. Even though each of these features, when taken in isolation, might conform to the Equipment Rules, it is the combination of these features which could lead to a non-conforming decision.

This is a good example of an area where rules officials should take care not to make decisions unless they are completely certain that it is correct. If, after examining the club and carrying out all of the appropriate consultations, it is still not possible to give a definitive ruling, a Duration of Competition or Duration of Round Answer should be given (see Supplementary Paper A – Advice to Rules Officials Concerning Queries on the Conformity of Clubs at Competitions).

The determination of a putter's "normal address position" or whether it can be used in a vertical or close-to-vertical position can be highly subjective and in terms of those putters which are actually submitted to The R&A or USGA, the job of making rulings on them is only made easier because it is possible to compare them with previous submissions and rulings.

Except for putters, all of the heel portion of the club must lie within 0.625 inches (15.88 mm) of the plane containing the axis of the straight part of the shaft and the intended (horizontal) line of play (see Fig. 12).

Fig. 12

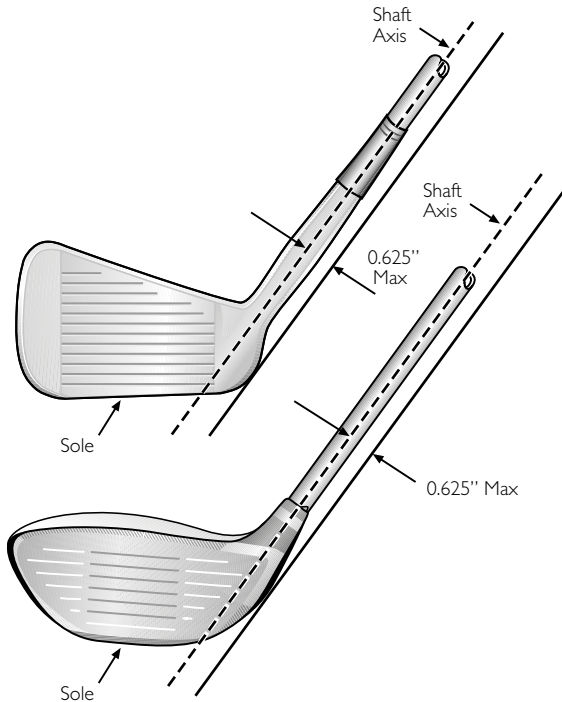

The intent of the provision is to prevent centre shafted clubs (see Section 2c below – “Attachment to the Clubhead”), and the measurement of an iron club is illustrated in Figure 13.

Fig. 13 – Shaft axis/heel measurement

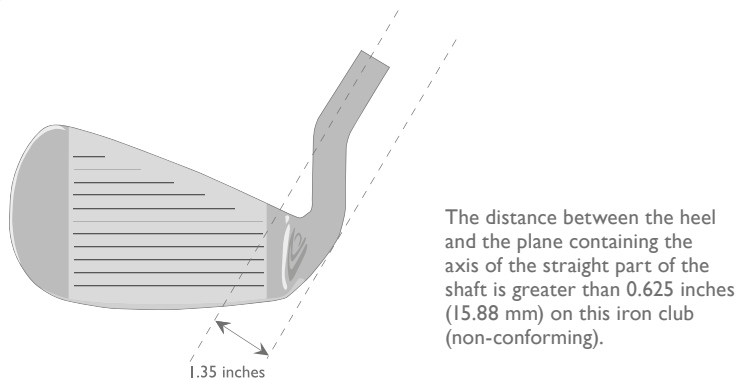

It is worth highlighting that the heel portion of the club extends from the face all the way to the back of the head. Therefore, for unusually shaped heads (e.g. flared or square shaped), where the outermost part of the heel may be further back from the face than for more traditionally shaped heads, the measurement will be completed at that point.

It is also worth stressing that, in most cases, the shaft of a putter may be attached at any point on the clubhead (see Section 2c).

## 2. Shaft

### a. Straightness

The shaft must be straight from the top of the grip to a point not more than 5 inches (127 mm) above the sole, measured from the point where the shaft ceases to be straight along the axis of the bent part of the shaft and the neck and/or socket (see Fig. 14).

This provision is interpreted to mean that the shaft must extend to the end of the grip, or at least that the grip should not extend beyond the top end of the shaft more than is necessary to accommodate the butt cap (see Figure 15).

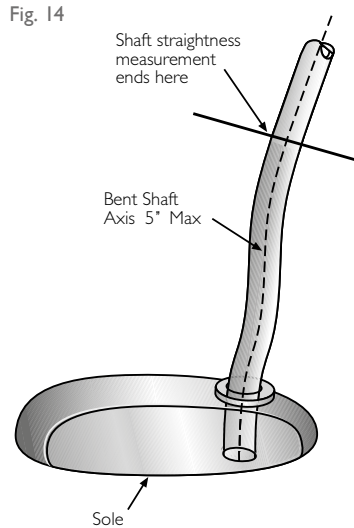
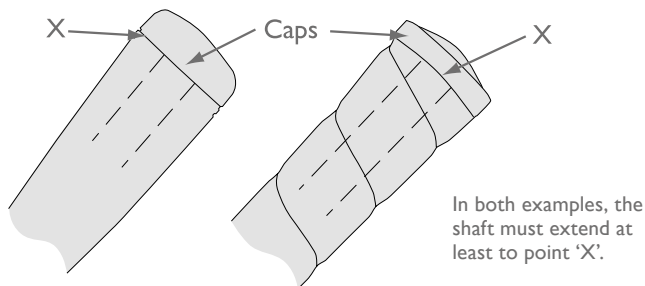
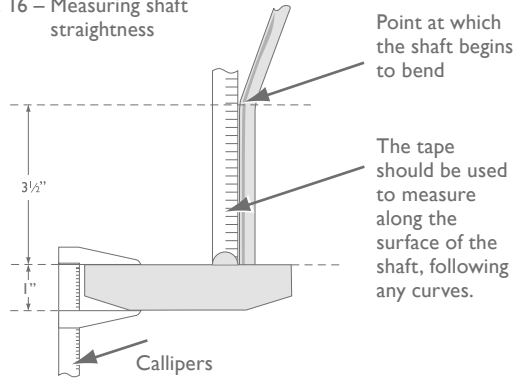

Fig. 15 – Illustrations of “butt caps”



The “5-inch” measurement should be made using a pair of callipers (to measure the depth of the head at the point where the shaft is attached) and a flexible measuring tape, or a piece of string (to measure the length of any bend or bends in the shaft from the point where the shaft ceases to be straight) (see Figure 16).

Fig. 16 – Measuring shaft straightness



The point where the shaft ceases to be straight can be determined by placing a rigid steel ruler along the straight part of the shaft and marking the point where the shaft and the ruler are no longer in contact. This provision is particularly relevant to putters where the shaft is inserted directly into the head. (For putter heads that have a “neck” – see Section 2c).

## b. Bending and Twisting Properties

At any point along its length, the shaft must:

- (i) bend in such a way that the deflection is the same regardless of how the shaft is rotated about its longitudinal axis; and
- (ii) twist the same amount in both directions.

This provision effectively restricts shafts from being designed to have asymmetric properties, so that irrespective of how the club is assembled, or whichever way the shaft is orientated, it will make no difference to the performance of the club. Clause (i) is interpreted to mean that the way in which the shaft deflects must be the same regardless of its orientation. It is not simply a measure of the magnitude of deflection.

It is challenging to assess the conformance of a shaft in the field. However, a standard shaft with a circular cross-section would most likely conform unless there is specific evidence to the contrary (e.g. claims by the manufacturer which indicate non-conformance, including advertising claims). A shaft which is not symmetrical in all axes (e.g. a shaft with an oval or rectangular cross-section) would not normally be expected to conform to the Equipment Rules. Manufacturers of shafts with unusual cross-sections or other unique features should submit them to The R&A or USGA for a ruling prior to marketing and/or manufacturing. Whether such a ruling exists can be confirmed by contacting The R&A or USGA.

Many graphite shafts have a small “spine” or “spines” running along the length of the shaft which may make them bend a little differently depending on how they are oriented during installation. The existence of a small spine is generally regarded as being the result of normal manufacturing processes and therefore not a breach of Section 2b. As previously noted, The R&A and USGA recognizes that it is difficult to produce a perfectly symmetrical shaft. Therefore, provided that the shaft is manufactured with the intention of meeting the above requirement, a reasonable tolerance is applied when evaluating shafts for conformance.

Manufacturers of clubs may orientate or align shafts which have spines for uniformity in assembling sets or in an effort to make the shafts perform as if they were perfectly symmetrical. However, a shaft which has been orientated for the purpose of influencing the performance of a club, e.g. to correct wayward shots, would be contrary to the intent of this provision.



### c. Attachment to Clubhead

The shaft must be attached to the clubhead at the heel either directly or through a single plain neck and/or socket. The length from the top of the neck and/or socket to the sole of the club must not exceed 5 inches (127 mm), measured along the axis of, and following any bend in, the neck and/or socket (see Fig. 17).

#### Exception for Putters:

The shaft or neck or socket of a putter may be fixed at any point in the head.

Fig. 17

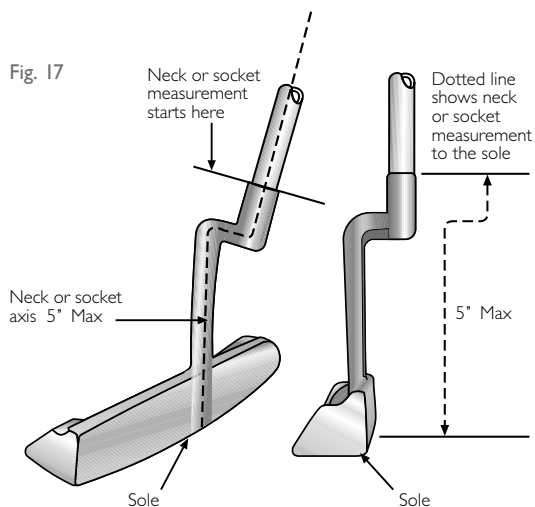

The most important points to remember here are that a club must only have one neck, that it must be “plain” and, in order to restrict elaborate shapes and curves, the length of the neck is limited to 5 inches (127 mm).

The interpretation of a “plain” neck is clarified as follows:

#### All clubs

The neck must not be shaped for any purpose, other than connecting the shaft to the head in a traditional manner. While a neck may contain features such as an adjustability mechanism, a method for damping vibration or an alignment line, it must not be unusually shaped in order to house or accommodate such a feature. For example, in most cases, lines which have been painted or lightly engraved onto an otherwise plain neck are permitted. However, a neck designed specifically to accommodate such lines or marks would be considered non-conforming. Small scale features, on an otherwise plain neck, which are purely for decorative purposes, and could not effectively perform, or be used for, another purpose, may also be permitted.

#### Woods

The above requirements also apply to woods, however there is some accommodation for the transition area between the head of a wood and its neck. This transition area must fit within a cylinder of a diameter and height of 1 inch (25.4 mm) measured from the base of the transition and parallel to the axis of the shaft. Any transition which satisfies this restriction should be permitted provided it does not contain any other non-plain feature (for example, holes or alignment bars).

**NOTE:** Some exceptions may be made for clubheads made of wood. Ferrules shaped to circumvent this interpretation are not permitted.

The measurement of the length of a neck should be made in the same way as a bend in the bottom of a shaft (see Section 2a and Figure 16).

The majority of necks are designed to have the shaft inserted into them, and this normally avoids any confusion as to where the neck begins. However, if the neck is inserted into the shaft, the measurement should be taken from the end of the shaft.

Figure 18 contains diagrams of various neck features which would not be permitted.

Fig. 18

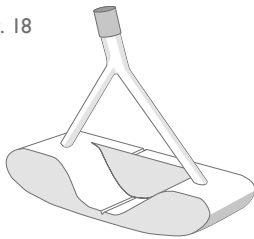

(a) Putter with two necks (non-conforming).

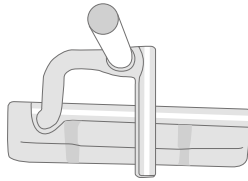

(b) Putter with aiming bar attached to the neck (non-“plain”, non-conforming).



(c) Putter with holes through the neck (non-“plain”, non-conforming).

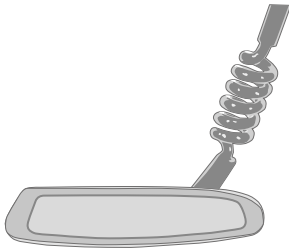

(d) The length of this spiral neck is measured following the axis of the bends and is longer than 5 inches and non-“plain” (non-conforming).

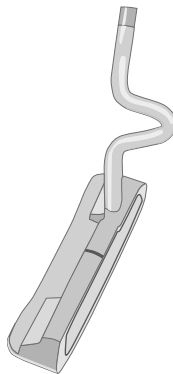

(e) Putter with forward protruding neck. If a neck protrudes forward of the face then the shaft connection must be made at the forward most point. This putter is contrary to that requirement (non-“plain”, non-conforming).

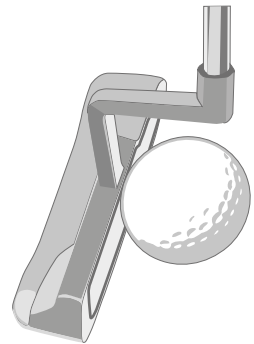

(f) If the shaft or the neck of a putter is attached to the head near the centre of the face, it must protrude forward of the face by no more than 0.84 inches (the radius of a ball). The neck on this putter extends forward by more than half of the ball (non-“plain”, non-conforming).

### 3. The Grip

#### a. Definition

The grip consists of material added to the shaft to enable the player to obtain a firm hold. The grip must be fixed to the shaft, must be straight and plain in form, must extend to the end of the shaft and must not be moulded for any part of the hands. If no material is added, that portion of the shaft designed to be held by the player must be considered the grip.

The grip is primarily for the purpose of assisting the player in obtaining a firm hold – so that the club does not slip or twist out of the player’s hands. However, the installation of a grip onto the shaft is optional.

When no material is added to the part of the shaft designed to be held by the player, the provisions relating to the grip take precedence over the provisions relating to the shaft. Therefore, the dimensions and cross-section of that area of the shaft could change (per Section 3b) and equal bending in any direction would not be required (so Section 2b does not apply in this case).

In order to accommodate both hands, the grip must be at least 7 inches (177.8 mm) in length. This also applies to clubs which have been designed to be used one-handed. For putters which have two grips, see Section 3c below.

Due to the nature of grips and the grip provisions, it is sometimes challenging to make a ruling without examining and comparing examples of other grips which are known to either conform or not conform. However, this is not something which would normally be possible in the field. It may help to remember that the overall consideration is that a grip “must not be moulded for any part of the hands”. If a certain feature on the grip enables the player to place his or her hands in exactly the same position every time, solely by feel, then it must be determined whether that feature renders the grip “moulded for the hands”. An extreme example of a grip which would be ruled “moulded for the hands” is the type of training grip often used to help beginners. However, a grip which has subtle changes in surface texture would usually be considered conforming. Likewise, printed markings which assist with the correct placement of the hands visually would normally be considered conforming. Most of the details contained in Sections 3b and 3c below serve to clarify and expand on this basic principle.

**b. Cross-section (See Fig. 19)**

- (i) For clubs other than putters the grip must be circular in cross-section, except that a continuous, straight, slightly raised rib may be incorporated along the full length of the grip, and a slightly indented spiral is permitted on a wrapped grip or a replica of one.
- (ii) A putter grip may have a non-circular cross-section, provided the cross-section has no concavity, is symmetrical and remains generally similar throughout the length of the grip. (See Section 3b(ii) explanation on p34).
- (iii) The grip may be tapered but must not have any bulge or waist. Its cross-sectional dimensions measured in any direction must not exceed 1.75 inches (44.45 mm).
- (iv) For clubs other than putters the axis of the grip must coincide with the axis of the shaft.

Fig. 19

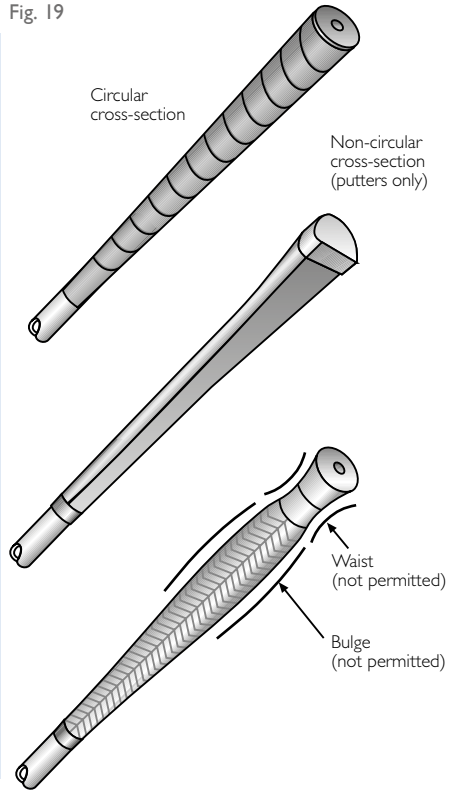

To take these each in turn:

**(i) Circular Cross-section for Woods and Irons**

Grips on woods and iron clubs are allowed to deviate from circular by having a slightly raised rib running along the full length of the grip (often called a “reminder rib”).

Fig. 20 – View from inside the grip

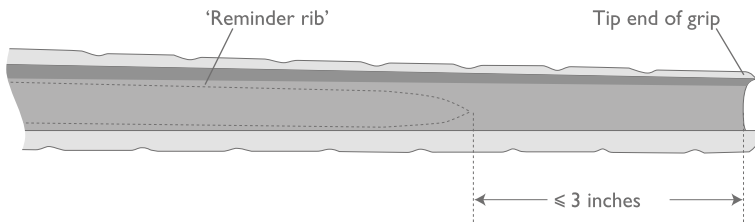

“Slightly raised” is interpreted to mean that the maximum and minimum diameters of the cross-section at any point must not differ by more than 0.040 inches (1.016 mm). While this measurement can be taken using a pair of callipers, due to the nature of gripping materials, the results of these measurements should be interpreted with caution in the field. An additional requirement, mainly for the benefit of manufacturers, is that the dimension of the rib width, from edge to edge, should not exceed 50% of the grip’s internal diameter.

In the case of a standard length grip (approximately 10 inches (254 mm) in length), the “full length of the grip” is interpreted to mean that the rib must extend to within 3 inches (76.2 mm) of the tip (see Figure 20). This should generally be enough to cover the span of the player’s hands on the grip.

Simulated leather wrapped grips moulded out of a rubber-like material with an indented spiral or other similar indentations are considered to be circular in cross-section and are permitted, as long as the fingers cannot comfortably fit in between the spirals or indentations. Similarly, features such as lines, dots or other patterned indentations, which are too small to fit even the smallest of fingers, would not of themselves render a grip non-circular in cross-section. However, any feature which is considered wide and deep enough to accommodate a finger or fingers could be ruled “moulded for the hands” and, hence, non-conforming.

## **(ii) Putters**

As clearly stated in this clause, a putter grip may have a non-circular cross-section, provided that, among other things, the cross-section remains generally similar throughout the length of the grip.

In order to accommodate the popular (and somewhat traditional) “pistol-type” putter grips and also limit the amount of potential offset, the phrase “generally similar” is interpreted to mean: (i) that the butt (top) end of the grip must not involve a sharp change in slope or dramatic flare on the underside (see Figures 21(a) and (b)); (ii) that the flat front must extend to within 1 inch (25.4 mm) of the top and bottom ends (see Figure 21(c)); and (iii) if the axis of the grip and the shaft do not coincide, the grip must be at least 10 inches (254 mm) in length.

As with circular grips, features such as lines, dots, or other patterned indentations, which are too small to fit even the smallest of fingers, would not of themselves render a putter grip not “generally similar throughout the length of the grip” or “moulded for the hands”.

Fig. 21

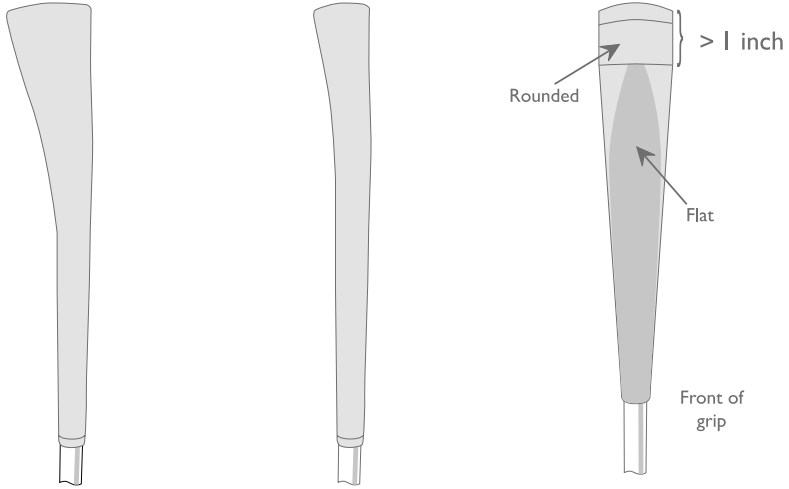

(a) – Non-conforming pistol grip, i.e. the flare is too dramatic.

(b) – Conforming pistol grip. Flat front is continuous throughout the length. The flare is not considered to be too dramatic.

(c) – Non-conforming pistol grip. The flat front does not extend to within an inch of the top.

### (iii) Cross-sectional Dimension

This clause is self explanatory, though it is important to note that the measurement may be made in any direction on the horizontal plane, including diagonally.

### (iv) Axis of the Grip

This clause requires that the axis of the circular grip on an iron or wood club coincides with the axis of the shaft. Therefore, a circular grip with the maximum diameter of 1.75 inches (44.45 mm) must not be mounted onto the shaft either off-centre or at an angle.

## c. Two Grips

A putter may have two grips provided each is circular in cross-section, the axis of each coincides with the axis of the shaft, and they are separated by at least 1.5 inches (38.1 mm).

If a putter were allowed to have two non-circular grips, it would be possible to mount the grips such that their cross-section would not be “generally similar” throughout the entire length (see Section 3b above). For this reason, putters which have two grips must have two circular grips and this is interpreted strictly such that the grips must not incorporate a reminder rib.

Where a putter has two grips, these grips are only considered separate if the gap between them is at least 1.5 inches (38.1 mm) in length. If a smaller gap exists, or if no gap exists, the total length from the bottom of the lower grip to the top of the upper one would be considered “one grip”. Therefore, it is unlikely that the grip would conform if two conventional circular grips were installed without the required gap. Either the exposed piece of shaft between the two grips would constitute a waist, or the point where the two grips meet in the middle would cause a bulge. If there was no gap between the upper and lower grip, the grip could conform if the lower grip is a continuation of the upper grip, i.e. a continuation of the same taper, and the transition between the two sections is smooth (see Figure 22(d)).

If a putter does have two separated grips, the upper grip must be at least 5 inches (127 mm) in length. If the grip does not satisfy this requirement, it would be considered to be “moulded for the hands”.

Note: It is worth emphasising that it is not permissible for wood or iron clubs to have more than one grip.

Fig. 22

(a) Two separate grips, both non-circular, lower grip mounted sideways (non-conforming).



(b) Two circular grips touching (non-conforming).

These grips need to be separated by at least 1.5 inches

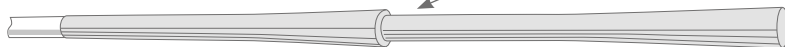

(c) Two circular grips too close (non-conforming).

Gap is less than 1.5 inches. Viewed as being one grip with waist

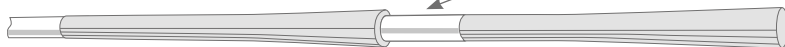

(d) Two circular grips touching (conforming).

Smooth joint – no waist or bulge. Continuation of the same taper.



## 4. Clubhead

### a. Plain in Shape

The “plain in shape” requirement originates from the ‘traditional and customary’ requirement in Section 1a. It is purely a descriptive provision, although in reality it can be challenging to define exactly what a golf club can or should look like. The following sections assist in explaining and illustrating what is and what is not permitted, but it should be noted that the examples that follow are not all-inclusive. Additionally, even if a clubhead satisfies all of the points outlined below, there may still be features or characteristics which render it not generally plain in shape. An overall assessment of the appearance of the head should always be made. The essence of Section 4a is encapsulated in the first three sentences of the general provision:

The clubhead must be generally plain in shape. All parts must be rigid, structural in nature and functional. The clubhead or its parts must not be designed to resemble any other object.

This provision basically means that the design of the clubhead must be free from gimmicks (though putters are viewed more liberally than woods and irons), must have the general appearance of a golf clubhead as opposed to another object and must not incorporate features which are designed to resemble another object (see Figure 23). All parts of the head (including permanent, permissible appendages) must be rigid throughout their length. As a general guideline, “rigid” means that it must not be possible to bend or flex the head or its parts by hand. (see Figure 24).

Fig. 23 – Facsimiles of other objects

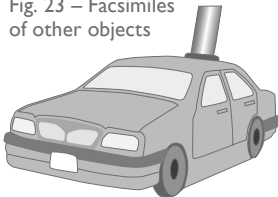

(a) Putter head in the shape of a car (non-conforming).

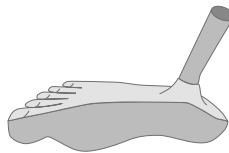

(b) Putter head in the shape of a foot (non-conforming).

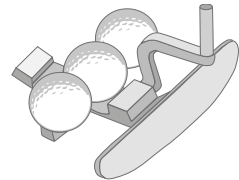

(c) Putter head incorporating three facsimiles of a golf ball (non-conforming).

Fig. 24

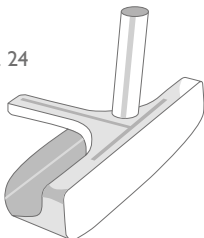

Putter with appendage for aiming/accommodating a sighting line. As long as the appendage is rigid, putter is conforming.



The general provision of Section 4a continues to state:

It is not practicable to define plain in shape precisely and comprehensively. However, features that are deemed to be in breach of this requirement and are therefore not permitted include, but are not limited to:

The above statement acknowledges that defining whether a clubhead is “plain in shape” is subjective. To better clarify the provision and its interpretation, it is split into two categories – one which covers “all clubs” and the other which covers the additional specifications relevant only to “irons and woods”. The Section also reflects the more liberalized application for putters which has evolved over the years and provides more detail regarding what is and what is not permitted for iron heads and woodheads.

Following are general guidelines and illustrations for the two categories of “plain in shape”:

#### (i) All Clubs

- holes through the face;
- holes through the head (some exceptions may be made for putters and cavity back irons);
- features that are for the purpose of meeting dimensional specifications;
- features that extend into or ahead of the face;
- features that extend significantly above the top line of the head;
- furrows in or runners on the head that extend into the face (some exceptions may be made for putters); and
- optical or electronic devices.

To take each of these clauses in turn:

#### Holes through the Face

Holes through the face are not permitted – see Figure 25.

Fig. 25

(a) Putter with holes in the face inset (non-conforming).



(b) Iron head with holes through the face (non-conforming).

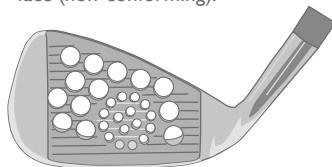

**Holes through the Head**

- Holes through the head are not permitted for wood heads – see Figure 26.
- Holes through the head are not permitted for iron heads. However, features within the cavity back of an iron clubhead that form a hole or holes may be permitted, (e.g. support bars), provided that the feature is contained within the outline of the main body of the head and the hole cannot be viewed from above – see Figure 27 a/b.

Fig. 26



Wood head with hole from crown to sole (non-conforming).

Fig. 27

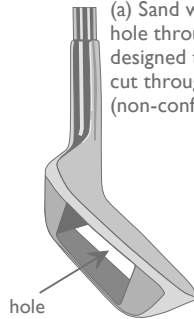

(a) Sand wedge with hole through the head designed to help head cut through the sand (non-conforming).

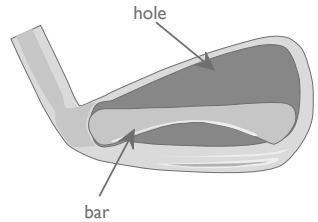

(b) The bar across the cavity back of this iron head creates a hole, but the feature is contained within the outline of the main body of the head (conforming).

- This provision is interpreted very liberally for putters and holes through the head (excluding the face) for any purpose including aiming, sighting or alignment are permitted – see Figure 28 for examples of permissible holes through the head of a putter.

Fig. 28



(a) Putter with hole extending from toe to heel (conforming).

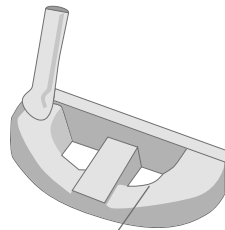

(b) Putter with vertical holes from top to bottom (conforming).

### Features for the purpose of meeting Dimensional Specifications

For all clubs, the distance from the heel to the toe of the clubhead must be greater than the distance from the front to the back (see Section 4b, below). Clubs which incorporate features which are designed to or have the effect of circumventing this requirement are not permitted – see Figure 29.

Fig. 29

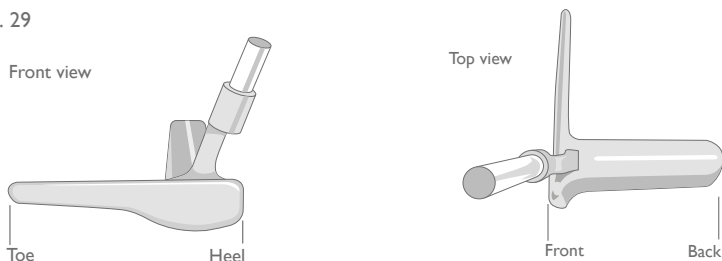

### Features that extend into or ahead of the face

- Permitted features in or on the main body of the head must not extend into the face of an iron or wood club. This would include alignment features on the crown – see Figure 30. Alignment lines which have been engraved or inscribed onto an iron clubhead would generally be permitted.

Fig. 30

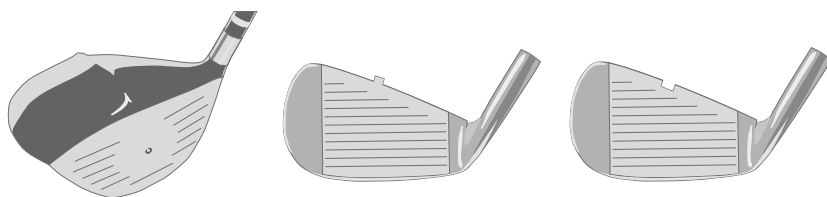

(a) Raised alignment feature on crown of head, which does not extend into the face (conforming).

(b) Iron head with raised alignment feature on the crown which extends into the face (non-conforming).

(c) Iron head with indented alignment feature on the crown which extends into the face (non-conforming).

- Certain features are permitted to extend into the face of a putter, including alignment features and concavities (or furrows) on the crown (see Section below on Furrows and Runners). However, such features must not have a depth or height greater than 0.25 inches (6.35 mm) when measured against the top line of the face.
- Features of any nature that extend ahead of the face are not permitted on any club – see Figure 31.

Fig. 31

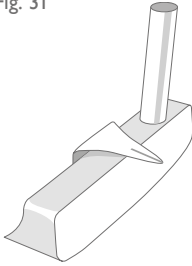

Putter with projection ahead of the face for aiming (non-conforming).

Fig. 32

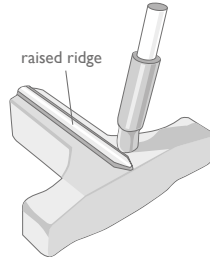

The alignment feature or ridge which extends above the top line of this face of this putter is less than 0.25 inches (6.35 mm) in depth. Therefore, putter is conforming.

### Features above the top line of the head

- For putters, alignment or other features must not extend above the top line of the face by more than 0.25 inches (6.35 mm) – see Figure 32.
- For woods and irons, features which otherwise meet the requirements for “plain in shape” must not extend above the top line of the head by more than 0.1 inch (2.54 mm).
- Permanent or semi-permanent lines or other markings which have been painted, inscribed or otherwise incorporated (see Section 1a) for alignment purposes are permitted.

### Furrows and Runners

- Furrows or runners which extend into the face of a wood or iron club from any part of the head are not permitted – see Figure 33.

Fig. 33

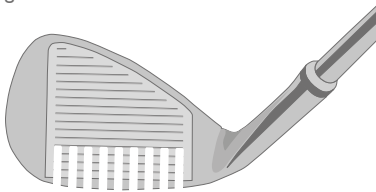

(a) Iron head with rake-like furrows in the sole – which extend into the face (non-conforming).

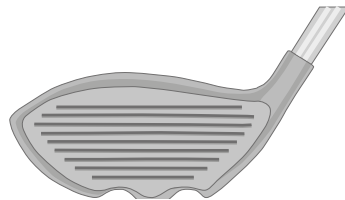

(b) Wood head with runners which extend into the face (non-conforming).

- While this provision is applied strictly for furrows or runners which may appear on the sole of a putter, exceptions may be made for other parts of the head – see Figure 34.

Fig. 34 Examples of putters with features on the top/crown of the head which extend into the face. These are permitted as long as they do not have a depth greater than 0.25 inches (6.35 mm).

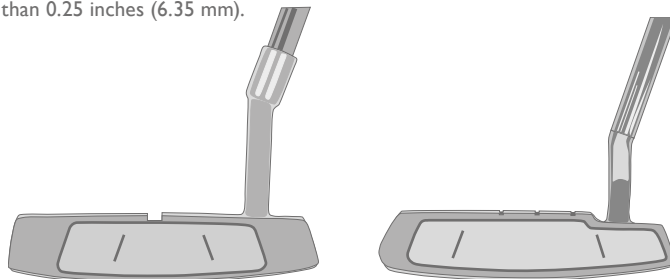

Furrows and/or runners are deemed to extend into the face if the leading edge of the face has any concavity (point of inflection or turning point).

The application of this provision is fairly straightforward in most cases and can be determined simply by placing a straight edge along the leading edge of the face and looking to see if there is a gap between these two edges. However, woods and hybrids commonly have a smooth transition between the face and the rest of the body which can sometimes make it difficult to determine, in a repeatable and reproducible manner, whether features “extend into” or intersect the face.

Where the transition between the body and the face is not clearly defined, i.e. the face does not meet the body at a sharp edge or chamfer, the *point of intersection* shall be defined as the point where a line inclined at 45° from the *reference plane* is tangent to the *cross-section* (see Figure 35).

Fig. 35

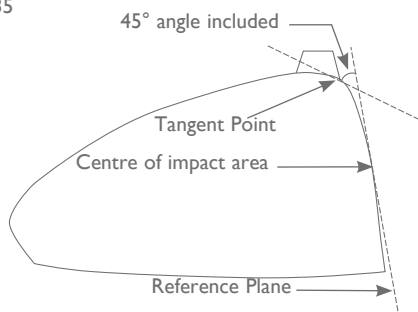

Example clubhead illustrating a tangent point defining the intersection between the face and body.

- A *reference plane* is defined as the plane tangent to the face at the centre of the impact area.
- A vertical cross-section is created by establishing a plane perpendicular to the reference plane, usually running through the centre of the face/clubhead and the area of interest (i.e. furrow or runner).

Projecting the points of intersection so defined onto the reference plane may be used to define a profile (see Figure 36).

Fig. 36

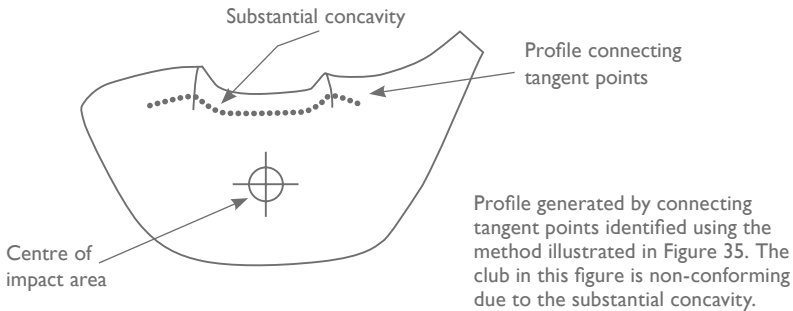

Any substantial concavities in said profile are considered sufficient evidence that a runner or furrow extends into the face and thus does not conform with Section 4a(i).

Where the transition between the body and face is clearly defined by a chamfer of at least  $45^\circ$  with respect to the face, furrows and/or runners are permitted to intersect the chamfered surface, provided the feature does not intersect the face itself (see Figure 37).

Fig. 37

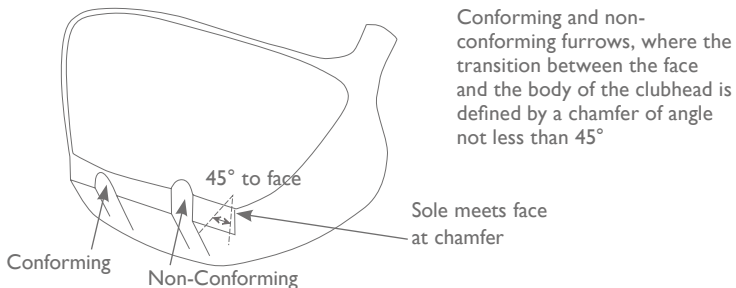

If a runner has been chamfered back away from the face, by at least 45°, then it would not be considered to extend into the face – see Figure 38.

Fig. 38a – Putter with runners at the heel and toe

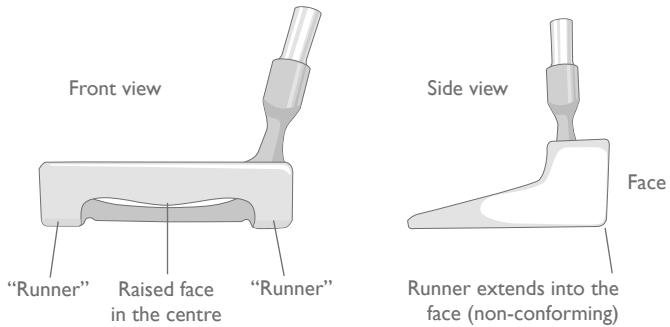
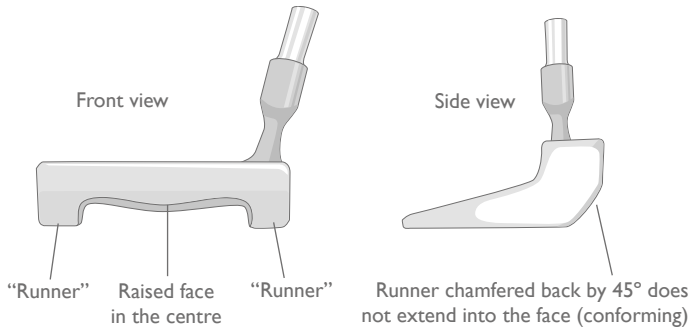

Fig. 38b – Putter with chamfered runners at the heel and toe



## Optical and Electrical Devices

Clubheads which incorporate prisms, mirrors, reflective materials, light beams, metronomes or mechanical devices such as spirit levels are not permitted – see Figures 39 and 40.

Fig. 39 – Optical devices

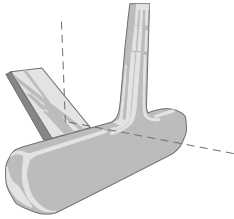

Putter head with sighting mirror attached to the back of the head at 45 degree angle to view target (non-conforming).

Fig. 40 – Electrical and mechanical devices

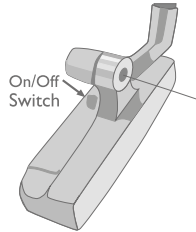

(a) Putter with laser beam sighting mechanism built into the head (non-conforming).

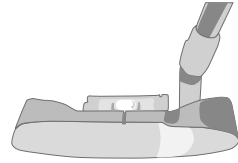

(b) Putter with spirit level at the back of the head (non-conforming).

Electronic devices in or on the club shaft or grip, which have the sole purpose of identifying the club, may be permitted. The identification information is restricted to:

- (a) the club's owner, such as address and phone number;
- (b) inventory tracking information;
- (c) detection of the club's use during a round.

Any such device must meet all other requirements of the Equipment Rules and must not vibrate or emit light or sound. If the device is capable of any function other than identification, the golf club will be considered not traditional and customary in form and make (see Section 1a (i)) and, therefore, non-conforming.

Note: Any device or application used in conjunction with a club incorporating such a device must comply with the provisions of Rule 4.3 of the Rules of Golf.



In addition to the provisions above, the “plain in shape” guidelines and illustrations for woods and irons are:

### (ii) Woods and Irons

- all features listed in (i) above;
- cavities in the outline of the heel and/or the toe of the head that can be viewed from above;
- severe or multiple cavities in the outline of the back of the head that can be viewed from above;
- transparent material added to the head with the intention of rendering conforming a feature that is not otherwise permitted; and
- features that extend beyond the outline of the head when viewed from above.

In essence, the purpose of these additional requirements is to help preserve the traditional shape and appearance of such clubheads when viewed from above. The “plain in shape” provisions for woods and irons are less focused on sole features or other features which cannot be viewed from above. To go through each of these provisions in turn:

#### Cavities in the Outline of the Heel and/or Toe

When making this assessment, “viewed from above” is interpreted to mean the range from directly above the head to the normal address position for that club. The restriction does not apply to horizontal cavities around the skirt of the head, which might be visible from above – see Figures 41a and b.

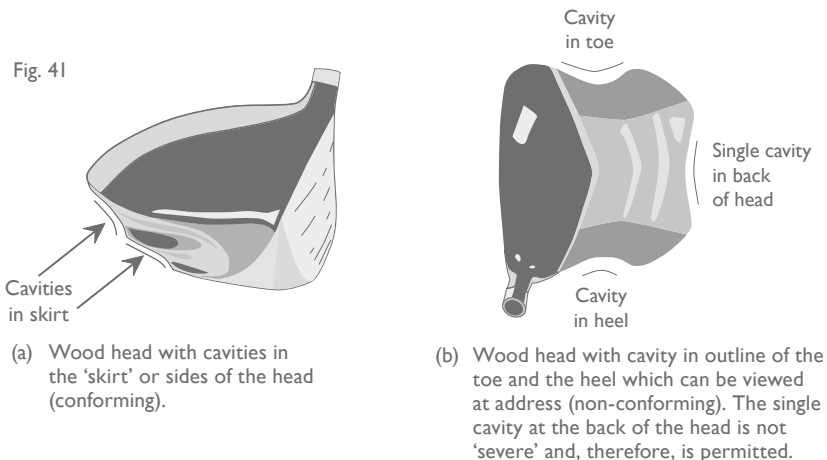

### Severe or Multiple Cavities in the Outline of the Back of the Head

- Severe cavities (as viewed at address), which go all the way through the head, are not permitted. A “severe” cavity is one where the entrance to the cavity is narrower than its width at any other point – see Figure 41c.
- A single cavity in the back of the head is permitted – see Figure 41b. However, multiple cavities are not permitted – see Figure 41d.
- Cavities in the crown of the head are permitted, even if they are designed primarily as an aid to sighting, aiming or aligning the swing plane or the head position, or to accommodate markings for such aids – see Figure 41e. However, all cavities on the crown are filled for the purpose of measuring the volume of the head – see Section 4b(i)).

Fig. 41 – cont.

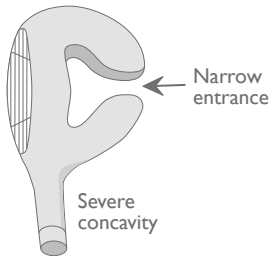

(c) Wood head with ‘severe’ concavity (non-conforming).

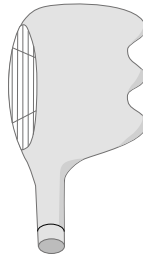

(d) Wood head with multiple cavities in outline of back of head (non-conforming).

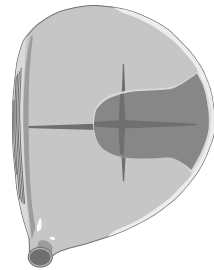

(e) Wood head with cavity in crown of head (conforming – with or without sighting lines).

### Transparent Material

- Clubheads made entirely of transparent material are permitted.
- Transparent material that is added to an otherwise non-plain head does not render the head “plain in shape”. For example, a wood head which has a vertical hole from the top surface through to the sole would be ruled non-conforming (see Section 4a(i) and Figure 26). Filling this hole with a transparent material (e.g. perspex or glass), would not alter this ruling.

### Features Extending Beyond the Outline of the Head

Any fin, knob, appendage or plate which is protruding beyond the outline of the head is not permitted, whatever the purpose.

NOTE: While this provision does not apply to putters, The R&A and USGA have determined that unusual features which protrude beyond the outline of the toe and/or heel of a putter head may be ruled not “plain in shape” or not “traditional and customary”. However, as previously noted, other permanent appendages to the putter head are permitted provided that:

- the feature is rigid throughout its length (i.e., cannot be bent or flexed by hand);
- the feature does not extend forward of the face; and,
- the features does not extend above the top line of the face by more than 0.25 inches (6.35 mm).

### b. Dimensions, Volume and Moment of Inertia

Section 4b is divided into three categories – woods, irons and putters.

The volume and moment of inertia limits apply only to woodheads.

#### (i) Woods

##### Dimensional specifications:

When the club is in a 60 degree lie angle, the dimensions of the clubhead must be such that:

- the distance from the heel to the toe of the clubhead is greater than the distance from the face to the back;
- the distance from the heel to the toe of the clubhead is not greater than 5 inches (127 mm); and
- the distance from the sole to the crown of the clubhead, including any permitted features, is not greater than 2.8 inches (71.12 mm).

These dimensions are measured on horizontal lines between vertical projections of the outermost points of:

- the heel and the toe; and
- the face and the back (see Fig. 42, dimension A); and on vertical lines between the horizontal projections of the outermost points of the sole and the crown (see Fig. 42, dimension B). If the outermost point of the heel is not clearly defined, it is deemed to be 0.875 inches (22.23 mm) above the horizontal plane on which the club is lying (see Fig. 42, dimension C).

Fig. 42

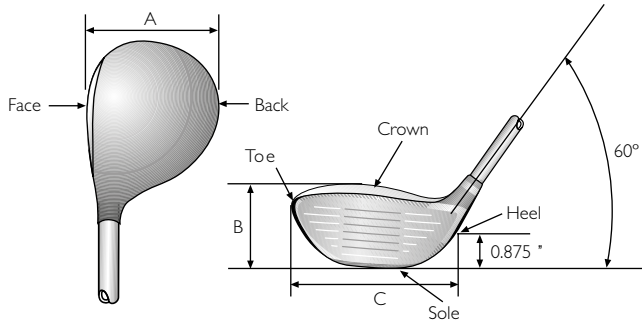

When performing these measurements in the field, the best method would be to use a pair of callipers. For the heel to toe measurement, a rigid, straight edge (e.g. a ruler) should be held upright against the extremity of the toe end.

#### Volume limit:

The volume of the clubhead must not exceed 460 cubic centimetres (28.06 cubic inches), plus a tolerance of 10 cubic centimetres (0.61 cubic inches).

In practice, many of the larger headed clubheads in the market place have a marking somewhere on the head indicating the approximate volume of the head (this is the cubic centimetres or “cc” value).

Fortunately, for clubs where there is no indication of volume, there is a fairly simple **method of determining the actual volume of a clubhead in the field** and it is broadly based on Archimedes’ Principle and the displacement of water. All that is needed is a large measuring container, half filled with water. The measure of clubhead volume would be the amount by which the water level rises once the clubhead has been submerged into the water. Therefore, if the container is filled with 1 litre of water and the level rises to 1450 millilitres when the head is submerged to the base of the hosel – this would mean that the head has a volume of 450 cubic centimetres.

The **official test protocol** for measuring volume is a more accurate method, but not that much more complicated, and it requires a similar container of water placed on a set of digital weighing scales.

Archimedes' Principle states that the buoyant force on a submerged object is equal to the weight of the fluid that is displaced by the object – and since water has a specific gravity of 1.0, this means that 1 cubic centimetre of water has a mass of 1 gram. Therefore, the container of water should be placed on the scales and the weight should be set to zero. When the head is submerged in the water, the weight displayed on the scales (in grams) is equivalent to the volume of the head (in cubic centimetres).

In situations where a club is marked with a “cc” value which is in excess of the Rule (i.e. above 460 cubic centimetres), The R&A's and USGA's policy is to rule that the club is non-conforming – regardless of the actual volume measurement. This is to avoid confusion in the marketplace.

Prior to measuring the volume of a clubhead, the head should be inspected for cavities. All cavities on the crown should be filled with waterproof clay or other similar material to create a 'straight line' which connects the edges of the cavity. The 'straight line filling technique' does not follow the taper or curvature of the surface of the head, rather the cavity is filled so that it becomes a flat surface which adjoins the outer edges.

Only significant concavities on the sole will be filled, meaning any cavity or series of cavities which have a collective volume of greater than 15 cc.

Fig. 43

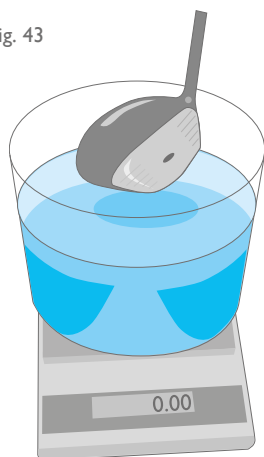

Electronic scales (set to zero) with water-filled container and club head ready for submergence.

### Moment of Inertia (MOI):

When the club is in a 60 degree lie angle, the moment of inertia component around the vertical axis through the clubhead's centre of gravity must not exceed 5900 g cm<sup>2</sup> (32.259 oz in<sup>2</sup>), plus a test tolerance of 100 g cm<sup>2</sup> (0.547 oz in<sup>2</sup>).

The MOI test is a measurement of a clubhead's resistance to twisting and, therefore, it is an indication of its 'forgiveness'.

The **measurement of MOI** is one of the few limits within the Equipment Rules which cannot easily be performed in the field. This is because the testing equipment is very specialized and it can only be measured by de-shafting the head (the hosel remains on the head for the purpose of the test). However, high MOI is only associated with modern, hollow, high volume driver heads and, due to the publication of the List of Conforming Driver Heads (see Rule 4c below), most of these clubs are now routinely submitted to the Governing Bodies for a ruling – so that they can be included on this List.

As the MOI of a driver head is affected by a change in its weight and the position of the centre of gravity, a driver which is designed to be adjustable for weight must conform to the Equipment Rules in all configurations (see Rule 1b). Moreover, when adding additional weight to a driver (e.g. with lead tape), the player must be certain that the club is still within the limit. To assist golfers with this determination, The R&A and USGA have developed a policy whereby if a driver head is submitted for a ruling and it is measured to have an MOI which is close to the limit, the manufacturer will be encouraged to advise its customers that the addition of any other weights to that model (including lead tape), other than the weights which were supplied by the manufacturer, is not permitted as it would likely render the club non-conforming. Additionally, the manufacturer must take care over its claims and must not advertise that the product is over the limit for MOI.

### (ii) Irons

When the clubhead is in its normal address position, the dimensions of the head must be such that the distance from the heel to the toe is greater than the distance from the face to the back.

In practice, due to the shape and size of iron heads, this provision is rarely encroached. It is retained in the Equipment Rules, in part, to help maintain the traditional shape by which irons are recognized. However, while most irons are still relatively narrow from front to back, the popularity of hybrid clubs means that this provision has greater utility today.

**(iii) Putters (see Fig. 44)**

When the clubhead is in its normal address position, the dimensions of the head must be such that:

- the distance from the heel to the toe is greater than the distance from the face to the back;
- the distance from the heel to the toe of the head is less than or equal to 7 inches (177.8 mm);
- the distance from the heel to the toe of the face is greater than or equal to two thirds of the distance from the face to the back of the head;
- the distance from the heel to the toe of the face is greater than or equal to half of the distance from the heel to the toe of the head; and
- the distance from the sole to the top of the head, including any permitted features, is less than or equal to 2.5 inches (63.5 mm).

Fig. 44

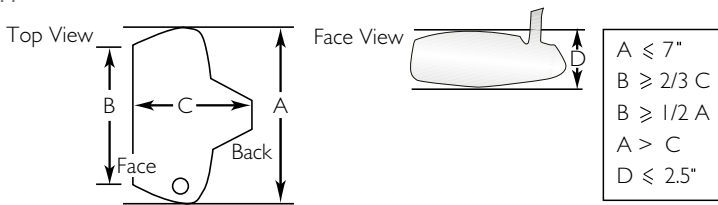

For traditionally shaped heads, these dimensions will be measured on horizontal lines between vertical projections of the outermost points of:

- the heel and the toe of the head;
- the heel and the toe of the face; and
- the face and the back;

and on vertical lines between the horizontal projections of the outermost points of the sole and the top of the head.

For unusually shaped heads, the toe to heel dimension may be made at the face.

Given all of the dimensional restrictions for putter heads, which help define the size and shape, the additional clause regarding unusually shaped heads is rarely, if ever, applied.

It is important to note that appendages are not permitted if their only purpose is to make the clubhead meet the dimensional specifications described in this provision (see Section 4a(iv) and Figure 29).

### c. Spring Effect and Dynamic Properties

The design, material and/or construction of, or any treatment to, the clubhead (which includes the club face) must not:

- (i) have the effect of a spring which exceeds the limit set forth in the Pendulum Test Protocol on file with The R&A and USGA; or
- (ii) incorporate features or technology including, but not limited to, separate springs or spring features, that have the intent of, or the effect of, unduly influencing the clubhead's spring effect; or
- (iii) unduly influence the movement of the ball.

**Note:** (i) above does not apply to putters.

Given that the “spring-effect rule” is purely a performance related limit which cannot be measured easily in the field without specialized equipment and cannot be assessed through a visual inspection of the clubhead, The R&A and USGA have compiled and maintain a **List of Conforming Driver Heads**. This List can be accessed via The R&A's or USGA's website and it is updated weekly.

For competitions involving highly skilled players, a **Model Local Rule** may be introduced requiring players to use a driver which is included on this List. This Local Rule is an additional requirement for these players, which means that, not only must their clubs conform to the Equipment Rules, but the model and loft must also be included on the List of Conforming Driver Heads. This Local Rule is not recommended for use at other levels of golf. However, it is the player's responsibility to ensure that his or her driver conforms to the Equipment Rules if it is not on the List.

As well as meeting the requirements of clause (i) in the above Rule, clubs are also tested for compliance to clause (ii) using the Pendulum at points on the face other than at the centre and, depending on the results, other tests may be carried out. Any club which is found to include a feature that is designed to act like a spring, independent of the level of flexibility achieved by the design, could be ruled non-conforming.

Finally, if claims of “spring like” qualities are made by the manufacturer which suggest that a club is manufactured to be in excess of the limit, or there is evidence to suggest that the club is indeed over the limit, then the club would be deemed to be non-conforming.



#### d. Striking Faces

The clubhead must have only one striking face, except that a putter may have two such faces if their characteristics are the same, and they are opposite each other.

The exception for putters was introduced in order to accommodate traditional blade-type putters.

Determining whether a surface constitutes a second (or third) striking face is often a matter of interpretation. However, in general, a surface should be considered an additional striking face if:

- the area is flat and it is clearly designed to be used for striking the ball; or
- it is opposite the intended face and consists of a flat surface of a different loft and/or material; or
- it is a flat surface on the toe and/or heel of a cylindrical, rectangular or square head design which could effectively be used to strike the ball; or
- it could otherwise effectively be used to strike the ball.

All three of the putters illustrated in Figure 45 would be ruled non-conforming.

Fig. 45

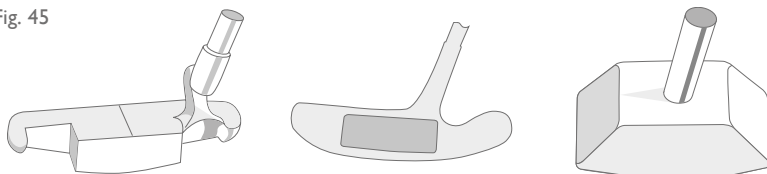

- (a) This putter has one small face at the front and a second much longer face at the back.
- (b) This putter has a 'balata' type inset in the front, but the back of the head is a smooth, flat metal surface.
- (c) This putter has two identical surfaces at the front and the back. However, it also has a third striking face at the toe.

The addition of lead tape to the secondary face of a dual-faced putter would not be contrary to the Equipment Rules. In addition, cosmetic or decorative markings on one of two permissible surfaces, that do not affect the performance, will not usually create a different striking face in breach of this provision.

## 5. Club Face

### a. General

The face of the club must be hard and rigid and must not impart significantly more or less spin to the ball than a standard steel face (some exceptions may be made for putters). Except for such markings listed below, the club face must be smooth and must not have any degree of concavity.

If claims of excessive spin are made by the manufacturer, or if there is strong supporting evidence of excessive spin, then the club would be deemed to be non-conforming.

The “hardness” provision is particularly relevant to putters, many of which have a urethane or other “soft” material inset in the face.

The measure for hardness is made using a durometer. A putter face must be no less than 85 on a Shore A scale durometer. A simple measure of hardness in the field would be to use a fingernail. If a fingernail leaves a significant imprint in the face of a club, it is possible that the material does not satisfy the “hard and rigid” requirement. The face of a wood or iron club must be substantially harder than a putter face, i.e. no less than 75 on the Shore D scale.

In the field, “rigidity” is interpreted to mean that the face should not have any visible signs of movement or flex when manual pressure is exerted.

Where there is an inset in the face of the club, it should be flush with the rest of the face so that the face can still be considered smooth with no concavity. While we interpret concavity in this provision strictly, we also recognize that, due to manufacturing tolerances, it is sometimes difficult for every insert to be exactly flush with the rest of the face. As a result, we allow an inset to be up to 0.006 inches (0.15 mm) proud of the rest of the face or no deeper than 0.004 inches (0.1 mm) below the rest of the face.

### b. Impact Area Roughness and Material

Except for markings specified in the following paragraphs, the surface roughness within the area where impact is intended (the “impact area”) must not exceed that of decorative sandblasting, or of fine milling (see Fig. 46).

The whole of the impact area must be of the same material (exceptions may be made for clubheads made of wood).

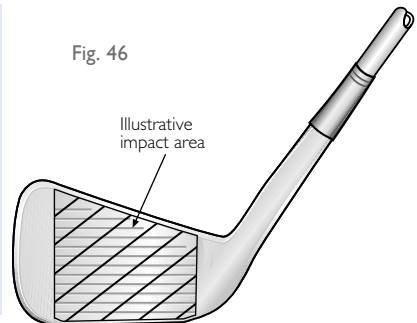

**(i) Definition of “Impact Area”****Irons**

For iron clubs, the “impact area” is deemed to be that part of the club face where a treatment has been applied (for instance grooves, sandblasting, etc.) or the central strip down the middle of the club face having a width of 1.68 inches (42.67 mm), whichever is greater.

**Woods**

The impact area on driving clubs and fairway woods is deemed to be the central strip down the middle of the clubface having a width of 1.68 inches (42.67 mm) – see Figure 47a.

Fig. 47 – Impact Area for Driving Clubs and Fairway Woods

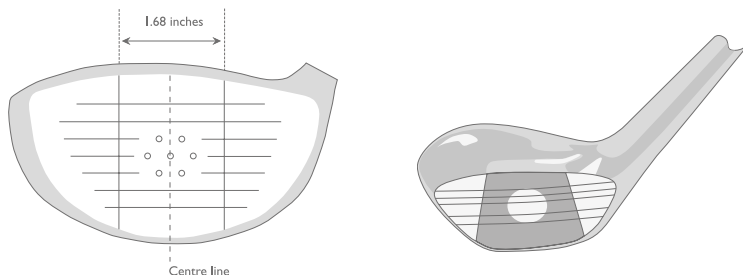

(a) Metal wood head showing size and shape of impact area.

(b) Grooves indicating traditional impact area

**NOTE:** Grooves and/or punch marks indicating a traditional impact area (see Figure 47b), or any groove which encroaches into the heel or toe portions of the impact area by less than 0.25 inches (6.35 mm), will not be considered to be within the impact area. However, any such markings must not be designed to unduly influence, or have the effect of unduly influencing, the movement of the ball.

For clubs with insets in the face, the boundary of the impact area is defined by the boundary of the inset, as long as any markings outside the boundary do not encroach the impact area by more than 0.25 inches (6.35 mm) and/or are not designed to influence the movement of the ball.

Moreover, the inset itself must extend to at least 0.84 inches (21.34 mm) either side of the centre line of the face and to within at least 0.2 inches (5.08 mm) of the top line and leading edge of the face.

**IMPORTANT NOTE:**

The above definitions of the impact area only apply to models of clubs manufactured on or after 1 January 2010. For clubs manufactured prior to 1 January 2010, please refer to the end of Supplementary Paper B.

**(ii) Impact Area Roughness**

When dealing with the surface roughness of a club face (not including putters, see Section 5f), the claims made by the manufacturer must be taken into account – especially if there is a claim that the roughness of the face influences the movement of the ball. In the absence of such claims, the ruling is made purely on the amount of roughness there is. Sandblasting or other treatments of roughness greater than 180 micro inches (4.5 µmetre) are not permitted. In addition to this requirement for roughness, milling is not permitted if the crest to trough depth exceeds 0.001 inches (0.025 mm). A reasonable tolerance is allowed for both of the above measurements. Non-conforming sandblasting or milling usually feels rough to the touch.

**(iii) Impact Area Material**

The requirement that the whole of the impact area must be of the same material does not apply to clubs made of wood or putters (see Section 5f). The reason why it does not apply to wooden headed clubs is to allow the continued use of traditional wooden clubs which have plastic insets and brass screws in the centre of the face. This design was commonly used in the old persimmon woods, some of which may still be in use. It is worth noting that a club face or inset made of a composite material would be considered to be of a single material and, therefore, would not be contrary to this provision.

Metal wood club faces which have insets of different material not trapezoidal in shape may be permitted if the height of the inset meets the definition of the impact area and the width of the inset is the same as the height in at least one point. However, in order to preserve the intent of the “same material” Rule, clubs which have unusually shaped insets of different material (i.e. other than circular, oval, square or rectangular) would not normally be permitted.

If an inset of different material is permitted under the above guideline, the inset would be considered the impact area for that club. Therefore, any markings outside that area need not conform to the specifications in Section 5c. However, such markings must not be designed to unduly influence the movement of the ball.

**c. Impact Area Markings**

If a club has grooves and/or punch marks in the impact area they must meet the following specifications:

**(i) Grooves**

- Grooves must be straight and parallel.
- Grooves must have a symmetrical cross-section and have sides which do not converge (see Fig. 48).

Fig. 48

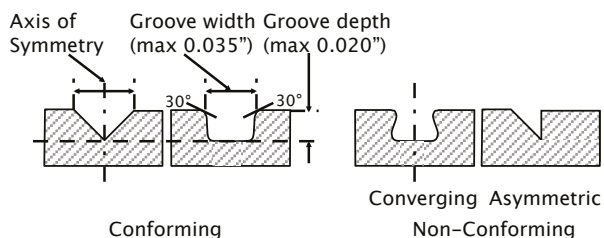

- \*For clubs that have a loft angle greater than or equal to 25 degrees, grooves must have a plain cross-section.
- The width, spacing and cross-section of the grooves must be consistent throughout the impact area (some exceptions may be made for woods).
- The width (W) of each groove must not exceed 0.035 inches (0.9 mm), using the 30 degree method of measurement on file with The R&A and USGA.
- The distance between edges of adjacent grooves (S) must not be less than three times the width of the grooves, and not less than 0.075 inches (1.905 mm).
- The depth of each groove must not exceed 0.020 inches (0.508 mm).
- \*For clubs other than driving clubs, the cross-sectional area (A) of a groove divided by the groove pitch (W+S) must not exceed 0.0030 square inches per inch (0.0762 mm<sup>2</sup>/mm) (see Fig. 49).

Fig. 49

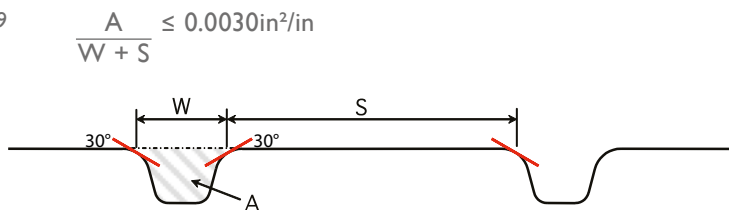

- Grooves must not have sharp edges or raised lips.
- \*For clubs that have a loft angle greater than or equal to 25 degrees, groove edges must be substantially in the form of a round having an effective radius which is not less than 0.010 inches (0.254 mm) when measured as shown in Fig. 50, and not greater than 0.020 inches (0.508 mm). Deviations in effective radius within 0.001 inches (0.0254 mm) are permissible.

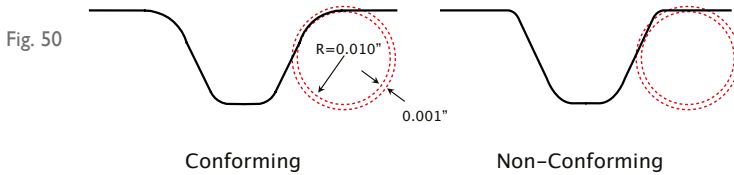

### (ii) Punch Marks

- The maximum dimension of any punch mark must not exceed 0.075 inches (1.905 mm).
- The distance between adjacent punch marks (or between punch marks and grooves) must not be less than 0.168 inches (4.27 mm), measured from centre to centre.
- The depth of any punch mark must not exceed 0.040 inches (1.02 mm).
- Punch marks must not have sharp edges or raised lips.
- \*For clubs that have a loft angle greater than or equal to 25 degrees, punch mark edges must be substantially in the form of a round having an effective radius which is not less than 0.010 inches (0.254 mm) when measured as shown in Figure 50, and not greater than 0.020 inches (0.508 mm). Deviations in effective radius within 0.001 inches (0.0254 mm) are permissible.

**Note 1:** The groove and punch mark specifications above indicated by an asterisk (\*) apply only to new models of clubs manufactured on or after 1 January 2010 and any club where the face markings have been purposely altered, for example, by re-grooving. For further information on the status of clubs available before 1 January 2010, refer to the “Equipment Search” section of [www.randa.org](http://www.randa.org) or “Club and Ball Lists” section of [www.usga.org](http://www.usga.org).

**Note 2:** The Committee may require, in the Model Local Rule, that the clubs the player carries must conform to the groove and punch mark specifications above indicated by an asterisk (\*). This Term is recommended only for competitions involving expert players. For further information, refer to the Committee Procedures, Section 8, Model Local Rule G-2 in The Official Guide to the Rules of Golf.

The groove and punch mark specifications were updated in 2010 and many pre-2010 models of clubs do not meet the new specifications. The above Notes mean that the vast majority of golfers can continue to carry clubs manufactured prior to 2010 until at least 2024.

Supplementary Paper B sets out guidance on how to measure width, depth and separation of grooves using the ‘ink and scratch’ method and how to determine the conformance status of a club to the pre-2010 Equipment Rules. This is an adequate method for use in the field where the Committee has not introduced the Groove and Punch Mark Model Local Rule (i.e. at the non-elite level).

There are several methods which can be used to measure grooves and punch marks against the updated specifications detailed above – most of which require specialized equipment.

Full details of the **procedure for measuring club face markings and determining their status against the post-2010 specifications** can be found on The R&A’s and USGA’s websites. A summary can also be found in Supplementary Paper C.

As noted, The R&A and USGA do not recommend adoption of the Model Local Rule referenced in Note 2 unless the competition involves professional-level players and/or players at the highest levels of amateur golf. In order to assist players and officials to determine whether a player’s clubs meet the condition, The R&A and USGA have compiled an **informational database** of irons, wedges, fairway woods and hybrids that have been submitted to either organization and evaluated for conformance to the updated specifications. This information is available on The R&A’s and USGA’s websites, respectively.

Notably, clubs where the face markings have been purposely altered, for example, by re-grooving must conform to the 2010 groove and punch mark specifications. However, clubs which have only been refurbished back to their original state (perhaps by light sandblasting) may still benefit from the period of grace given to pre-2010 models.

For the avoidance of doubt, all new models available after 31 December 2009 must conform to the current Equipment Rules.

### (iii) Groove/Punch Mark Combinations

If punch marks are used in conjunction with grooves, the following guidelines apply:

#### Iron Clubs

- Small punch marks which are in line with a conforming groove, and which would be totally contained within a continuation of the groove do not have to meet the punch mark to groove specifications (See Figure 51). However, if the diameter of such punch marks exceeds the width of the groove, then they must meet the specifications.

Fig. 51

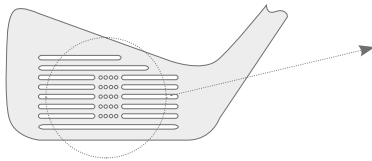

The diameter of these punch marks is smaller than the width of the grooves.



Therefore, if these grooves conform, the 'punch mark to groove separation Rule' does not apply.

Fig. 52

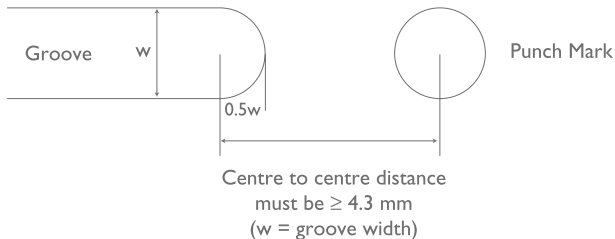

- When measuring the centre to centre distance between a punch mark and the end of an in-line groove, the centre of the groove is deemed to be half a groove width from the end edge of the groove (See Figure 52).

#### Metal Wood Clubs

Provided the following three conditions are satisfied, the above interpretation of the specifications for punch marks in line with a groove may also be granted for metal woods, even if the punch marks would not be totally contained by the continuation of the groove:

- there must be no more than three in-line punch marks in the part of the groove that is missing (i.e. in the gap between the ends of the partial grooves);



- the combined area of all of the in-line punch marks in any one such gap must not exceed the area of the missing groove; and
- the separation of the in-line punch marks from adjacent parallel grooves – measured from centre to centre – must be at least four times the width of the groove.

Fig. 53 illustrates each of the above conditions:

Fig. 53 – Exceptions for Metal Woods

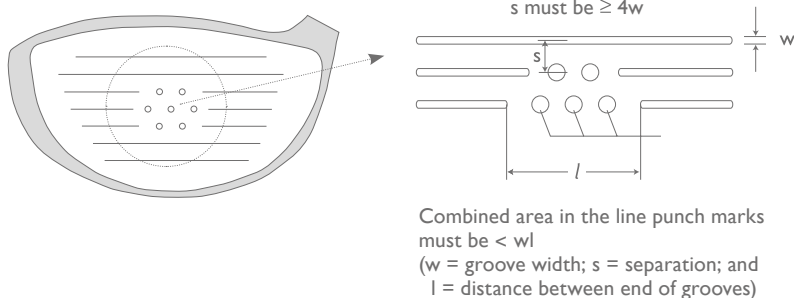

#### d. Decorative Markings

The centre of the impact area may be indicated by a design within the boundary of a square whose sides are 0.375 inches (9.53 mm) in length. Such a design must not unduly influence the movement of the ball. Decorative markings are permitted outside the impact area.

This provision permits small, decorative logos in the centre of the face or at the side of the impact area (see Fig. 54). Decorative markings or logos that marginally encroach on the impact area, i.e. by less than 0.25 inches (6.35 mm), may be permitted. However, any such markings must not be designed to unduly influence or have the effect of unduly influencing the movement of the ball. Markings outside the impact area which are designed to influence the movement of the ball when it has been mis-hit would be contrary to this provision.

Fig. 54 – Decorative Markings

The decorative marking in the centre fits into the boundaries of a square whose sides are 0.375" (9.52 mm) in length, and thus conforms with the Rules. However, the word "Accuracy", is deemed to significantly encroach on the impact area, and therefore the club is non-conforming.

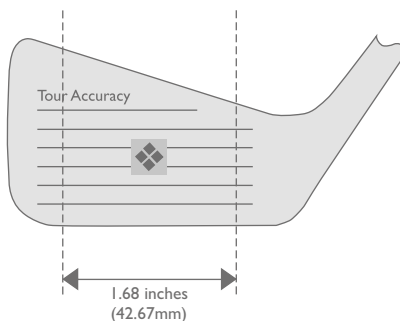

#### e. Non-metallic Club Face Markings

The above specifications do not apply to clubheads made of wood on which the impact area of the face is of a material of hardness less than the hardness of metal and whose loft angle is 24 degrees or less, but markings which could unduly influence the movement of the ball are prohibited.

#### f. Putter Face

Any markings on the face of a putter must not have sharp edges or raised lips. The specifications with regard to roughness, material and markings in the impact area do not apply.

In addition, if a groove or the grooves on the face of a putter exceed 0.035 inches (0.9 mm) in width and 0.020 inches (0.508 mm) in depth, the following guidelines apply:

- The width may not exceed 0.060 inches (1.524 mm);
- The width to spacing ratio must be no less than 1:1; and
- The depth must be less than the width, and may not exceed 0.040 inches (1.016 mm).

## PART 3 – THE GOLF BALL PLAYING RULES

### 4.2 Balls

#### a. Balls Allowed in Play of Round

(1) **Conforming Ball Must Be Played.** In making each stroke, a player must use a ball that conforms to the requirements in the Equipment Rules.

A player may get a conforming ball to play from anyone else, including another player on the course.

(2) **Deliberately Altered Ball Must Not Be Played.** A player must not make a stroke at a ball whose performance characteristics have been deliberately altered, such as by scuffing or heating the ball or by applying any substance (other than in cleaning it).

Markings applied using a felt-tip pen are not contrary to Rule 4.2a(2).

Rule 6.3a encourages the player to put an identification mark on his or her ball to help ensure that he or she plays their own ball throughout the round. There are no regulations to limit what or how many markings can be applied to the ball by the player, provided its original markings can be discerned.

#### **The List of Conforming Golf Balls**

Manufacturers may submit balls to The R&A and USGA for testing. Twenty-four samples of each ball type or model must be submitted to obtain a conformance ruling. If the samples conform to the Equipment Rules, the model is included on the List of Conforming Golf Balls, which is updated on a monthly basis. The current list can be found on The R&A's and USGA's websites. Full details of the golf ball submission procedure can be obtained from The R&A or USGA.

Balls remain on the List for one year. Random tests are carried out by The R&A and USGA on selected balls to ensure that the ball characteristics remain the same. If a conformance issue is identified during random testing, the ball may be removed from the list.

Normally, only the Committees in charge of competitions involving expert players (professional-level players and/or players at the highest levels of amateur golf) should introduce a Model Local Rule requiring a player to use a ball included in the List of Conforming Golf Balls, the penalty for breach of the Local Rule being disqualification. However, if this Local Rule is not in place, then the assumption is that a ball used by a player conforms unless there is strong evidence to the contrary e.g. a player used a 1.62 inch diameter golf ball (a ball which used to be in circulation and was permitted under the Rules before finally being prohibited worldwide in 1990).

## PART 4 – CONFORMANCE OF BALLS

### General

The Rules and specifications regarding the golf ball are divided into the following six categories:

- |            |                              |
|------------|------------------------------|
| 1. General | 4. Spherical Symmetry        |
| 2. Weight  | 5. Initial Velocity          |
| 3. Size    | 6. Overall Distance Standard |

### I. General

The ball must not be substantially different from the traditional and customary form and make. The material and construction of the ball must not be contrary to the purpose and intent of the *Rules*.

Prior to 2008, all of the provisions on the golf ball were precise and quantitative in comparison to the generally more descriptive Equipment Rules that relate to clubs. However, in 2008, new language was introduced to protect against any new technology which may be developed in the future which circumvents the intent of the existing Equipment Rules. Therefore, along with the guidelines and specifications listed below, The R&A or USGA may conduct additional testing and inspections to identify whether golf balls contain unusual material, construction and/or performance characteristics which might be considered substantially different from the traditional and customary form and make and/or contrary to the purpose and intent of the Equipment Rules.

### Golf Ball Construction

Only golf balls constructed entirely from elastomeric materials (i.e., viscoelastic materials having a low elastic modulus) will be considered to be of traditional and customary form and make. Allowance may be made for the presence of some traces of non-elastomeric materials. The elastomeric materials may be thermoset or thermoplastic polymers, but must not be designed or manufactured to facilitate intentional modification of the ball's playing characteristics. In addition, the design of the golf ball may not include parts or components that move with respect to each other or the ball or that are not concentric with the golf ball. Exceptions to the requirement that the ball must not be substantially different from the traditional and customary form and make are noted below.

**Exceptions:**

Golf balls may have a single, concentric core with a diameter of  $\leq 0.9$ -in (22.9mm), provided that the core:

- contains fluid constrained within a single chamber; OR
- if non-elastomeric, is effectively rigid (such as a solid or hollow, thick shell metallic sphere)

An embedded computer chip may be permitted within the ball for identification purposes, provided that the ball meets all other conformance requirements.

**2. Weight**

The weight of the ball must not be greater than 1.620 ounces avoirdupois (45.93 g).

This is one of the simpler tests, as all that is required is an accurate set of scales. There is no minimum weight thus a ball can be as light as the manufacturer desires.

**3. Size**

The diameter of the ball must not be less than 1.680 inches (42.67 mm).

The official test protocol uses a metal ring gauge suspended in perspex. It is important to note that there is no maximum size, the ball can be as large as desired provided it conforms to all other standards.

**4. Spherical Symmetry**

The ball must not be designed, manufactured or intentionally modified to have properties which differ from those of a spherically symmetrical ball.

The intent of this provision is simply to ensure that a ball is manufactured and designed to behave symmetrically.

**5. Initial Velocity**

The initial velocity of the ball must not exceed the limit specified under the conditions set forth in the Initial Velocity Standard for golf balls on file with The R&A and USGA.

There is a formal test procedure carried out using equipment approved by The R&A and USGA to evaluate whether golf balls meet the Initial Velocity specification. The intent of the provision is to limit the speed of the ball off the clubface. Full details of the test specification are available on The R&A's or USGA's website.

## 6. Overall Distance Standard

The combined carry and roll of the ball, when tested on apparatus approved by The R&A and USGA, must not exceed the distance specified under the conditions set forth in the Overall Distance Standard for golf balls on file with the R&A and USGA.

This provision was first introduced in 1976 in order to restrict the overall distance (carry and roll) a ball can travel under certain specific conditions. This test protocol is continuously reviewed to ensure that it reflects the modern game and modern equipment.

## PART 5 – EQUIPMENT PLAYING RULES

### Rule 4.3 Use of Equipment

Rule 4.3 applies to all types of equipment that a player might use during a round, **except** that the requirement to play with conforming clubs and balls is covered by Rules 4.1 and 4.2, not by this Rule.

This Rule only concerns how equipment is used. It does not limit the equipment that a player may have with him or her during a round.

#### 4.3a. Allowed and Prohibited Uses of Equipment

A player may use equipment to help his or her play during a round, **except** that a player must not create a potential advantage by:

- Using equipment (other than a club or a ball) that artificially eliminates or reduces the need for a skill or judgment that is essential to the challenge of the game, or
- Using equipment (including a club or a ball) in an abnormal way in making a stroke. “Abnormal way” means a way that is fundamentally different than its intended use and is not normally recognized as part of playing the game.

This Rule does not affect the application of any other Rule that limits actions a player is allowed to take with a club, ball, device or other equipment (such as setting down a club or other object to help the player in lining up, see Rule 10.2b(3)).

Common examples of uses of *equipment* that are allowed and not allowed during a player’s *round* under Rule 4.3 are provided in the Rules of Golf.

## PART 6 – DEVICES AND OTHER EQUIPMENT

The following paragraphs prescribe general regulations for the design of devices and other equipment, together with specifications and interpretations. They should be read in conjunction with Rule 6.2 (Teeing) and Rule 4.3 (Use of Equipment) of The Rules of Golf.

### 1. Tees (Rule 6.2)

A tee is a device designed to raise the ball off the ground. A tee must not:

- be longer than 4 inches (101.6 mm);
- be designed or manufactured in such a way that it could indicate *line of play*;
- unduly influence the movement of the ball; or
- otherwise assist the player in making a *stroke* or in his play.

**Note:** As an exception for difficult turf conditions, tees tethered together or to an anchor may be used during the round provided that the player does not align the tees or tether in such a way that could indicate line of play or otherwise assist the player in making a stroke.

### 2. Gloves (Rule 4.3)

Gloves may be worn to assist the player in gripping the club, provided they are plain.

A “plain” glove must:

- consist of a fitted covering of the hand with a separate sheath or opening for each digit (fingers and thumb); and
- be made of smooth materials on the full palm and gripping surface of the digits.

A “plain” glove must not incorporate:

- material on the gripping surface or inside of the glove, the primary purpose of which is to provide padding or which has the effect of providing padding. Padding is defined as an area of glove material which is more than 0.025 inches (0.635 mm) thicker than the adjacent areas of the glove without the added material;

**Note:** Material may be added for wear resistance, moisture absorption or other functional purposes, provided it does not exceed the definition of padding (see above).



- straps to assist in preventing the club from slipping or to attach the hand to the club;
- any means of binding digits together;
- material on the glove that adheres to material on the grip;
- features, other than visual aids, designed to assist the player in placing his hands in a consistent and/or specific position on the grip;
- weight to assist the player in making a *stroke*;
- any feature that might restrict the movement of a joint; or
- any other feature that might assist the player in making a *stroke* or in his play.

### 3. Shoes (Rule 4.3)

Shoes that assist the player in obtaining a firm stance may be worn.

Subject to the conditions of competition, features such as spikes on the sole are permitted, but shoes must not incorporate features:

- designed to assist the player in taking his *stance* and/or building a *stance*;
- designed to assist the player with his alignment; or
- that might otherwise assist the player in making a *stroke* or in his play.

### 4. Clothing (Rule 4.3)

Articles of clothing must not incorporate features:

- designed to assist the player with his alignment; or
- that might otherwise assist the player in making a *stroke* or in his play.

**Use of Compression Clothing:** Compression clothing has been available for many years and its use is widespread in both the winter and summer for temperature regulation and sun protection. Compression garments are not considered unusual equipment and consequently are permitted under Rule 4.3.

**Use of Posture Garments (e.g., shirts):** Posture garments, as currently available (2012), are considered to be a type of compression garment and should be permitted under Rule 4.3. These include: Posture shirts, Posture/sports bras, Girdles, and Shaping undergarments.

Clothing incorporating features designed to or which have the effect of: Storing and releasing energy, or Inhibiting or enhancing movement, are considered unusual equipment in breach of Rule 4.3.

## 5. Use of Tape, including Kinesiology Tape (Rule 4.3)

In general, tape or similar coverings (including kinesiology tape) may be used for medical reasons, provided it is not used in an excessive manner and the Committee is satisfied that its use does not give the player any undue advantage. However, if the adhesive tape or similar covering is used for other than medical reasons and in a manner that might assist a player in gripping the club or making a stroke it would be considered use of equipment in an unusual manner in breach of Rule 4.3.

## 6. Distance Measuring Devices (Rule 4.3)

The allowed usages of Distance Measuring Devices (DMDs) are identified under Rule 4.3a(1), (2) and (3). More detailed information and examples can be found on either the R&A's or USGA's websites.

## 7. Definition of Alignment Device and Treatment of Ball-Markers (Rule 4.3)

The following criteria are used to determine when an object manufactured to mark the spot of a ball is an alignment device. Features include, but are not limited to:

- The object incorporates features designed to measure, gauge or interpret slope, green speed or other conditions, or includes optical or electronic components or,
- The vertical height of the object, in any configuration, is greater than 1.0" or,
- The maximum dimension in any horizontal direction exceeds 2.0" and incorporates any of the features noted below (or similar features):
  - o the object incorporates painted, etched or inscribed line(s) or similar features greater than or equal to 2.0" in length ("line" includes any line, arrow or other straight marking that could be solid or broken, but has a defined start, a defined end and whose length can be measured),
  - o the object has an appendage(s) or an extended feature(s) greater than 2.0" in length or that extends a feature of the object to a length greater than 2.0".

Note 1: An object is an alignment device if it exceeds the dimensional specifications listed above and advertising, marketing or intellectual property descriptions or claims related to the object indicates that it is primarily for the purpose of showing the line of play.

Note 2: An object is an alignment device if it is modified in any manner that would satisfy any of the above provisions.

## PART 7 – MODIFIED EQUIPMENT RULES FOR PLAYERS WITH DISABILITIES

### Rule 25 – Modifications for Players with Disabilities

The full text of Rule 25 can be found in the Rules of Golf.

A number of players have physical limitations that may result in some degree of disability and that may affect their ability to play the game. Rule 25 allows a player with a disability to compete fairly with players who have no disabilities, the same disability or different disabilities.

For the most part, the modifications covered in Rule 25 are such that there is no allowance for modification to clubs, balls, devices or other equipment. However, there are some cases where a modification is required.

There are two cases where a modification to a club or other equipment could be allowed without consultation with the R&A or USGA, but only if the Committee is of the opinion that it is warranted and does not provide the player with an undue advantage.

#### 1. Length

Players who can demonstrate a need to use clubs that are longer than the 48-inch (1.219m) limit defined in Part 2 Section 1c may use clubs longer than 48 inches (1.219m) in length, provided that the shortest club carried by the player (excluding the putter) is no more than 10 inches (254 mm) shorter than his or her longest club (again, excluding the putter) and the Local Committee authorizes it. This is the same allowance included in Part 2 Section 1c of the Equipment Rules.

#### 2. Grips

Players who have a physical limitation, such as missing digits or other medical condition restricting the use of one or both hands, may be permitted to use grips on their clubs which do not meet the requirements of Part 2 Section 3 of the Equipment Rules, provided that the Local Committee determines that the player would not gain an undue advantage over other players. The grips to be used should be commercially available (e.g. putter grips) not modified in any way, and should not generally be manufactured in such a way that they would be considered to be a “training grip” i.e. a grip that is designed to place the hands in a consistent position or assist with the stroke.

Other grip modifications may be permitted under Rule 4.3b.(1), but in these instances it is highly recommended that the Committee consults with the R&A or USGA before giving an allowance.

## PART 8 – COMMITTEE EQUIPMENT REQUIREMENTS

This section covers items of equipment which are not a player's responsibility, but that are used by the player during the round. These items may still be required to meet certain specifications to allow the game to be played to the Rules of Golf. It is the responsibility of the Committee to ensure that all such items of equipment meet the requirements laid out in this section.

### I. The Flagstick

The flagstick is provided by the Committee and is placed in the hole to show players where the hole is. The flagstick comprises a removable pole and other components attached to the pole as defined below. None of the components of the flagstick may be designed to, or include features that unduly influence the movement of the ball or allow a player to measure wind speed or direction.

#### Requirements:

##### a. The Pole

- i. Must be circular in cross-section.
- ii. Must have a diameter of no greater than 2 inches (50.8 mm) from the top of the pole to a point no less than 3 inches (76.2 mm) above the putting green surface.
- iii. Must have a constant diameter of no greater than 0.75 inches (19 mm) from a point 3 inches (76.2 mm) above to 3 inches (76.2 mm) below the putting green surface.
- iv. Must not incorporate features, including its material composition, designed to act in a shock absorbing manner or have shock absorbing properties upon impact with the ball.

##### b. The Flag and Ornamental Attachments

- i. Must be of reasonable size and be located near the top of the pole.
- ii. Can indicate but must not measure wind direction and speed; and must not have any functional purpose other than to aid identification of the location of the hole.
- iii. Attachments to the flag are not permitted.

### c. Other Attachments

- i. Attachments to the pole may be permitted more than 3 inches (76.2 mm) below the putting green surface but must be constrained to this area.
- ii. Attachments to the pole may be permitted more than 3 inches (76.2 mm) above the putting green surface provided that they fall within at least one of the following categories:
  - a. Indicators of a reasonable size used to identify the location of the flagstick on the green (e.g. front, middle, back);
  - b. Reflectors and similar attachments of a reasonable size for use with distance-measuring devices are permitted;
  - c. Attachments to the pole other than those specified in a and b that are generally circular in cross-section and no greater than 2 inches (50.8 mm) in dimension perpendicular to the pole.

Note: Specifications relative to the putting green surface are based on the flagstick being located correctly in the hole.

## Supplementary Paper A

### ADVICE TO RULES OFFICIALS CONCERNING QUERIES ON THE CONFORMITY OF CLUBS AT COMPETITIONS

#### Introduction

It is the player's responsibility to ensure that his or her clubs conform with the Rules and if in doubt about a particular club, he or she would be well advised not to use it. However, such advice is not always appropriate, particularly when a query arises during or after a competition, in which case a decision is required.

#### Notes on Terminology Used

- "R&A or USGA Decision" is one which already exists in The R&A or USGA Equipment Standards database or Official Guide to the Rules of Golf at the time the query arises, though maybe unknown to the player or Official concerned.
- "R&A or USGA Ruling" is one that The R&A or USGA Equipment Standards Committee or its authorized sub-Committee may make on the club which is the subject of the query. It is made after the query has been communicated to the appropriate Equipment Standards representative, whether it be before, during or after the competition.
- "Duration of Competition Answer" is made by an Official involved in running a stroke-play competition. "Duration of Competition Answers" have no standing beyond the end of the competition and, therefore, the player should be advised to submit the club to The R&A or USGA for an official conformance determination prior to using the club in subsequent competitions. The player should also be made aware that any subsequent ruling may be different from the Duration of Competition Answer which was given.
- "Duration of Round Answer" is usually made by an Official involved in running a match play competition. "Duration of Round Answers" have no standing beyond the end of the round and, therefore, the player should be advised to submit the club to The R&A or USGA for an official conformance determination prior to using the club in subsequent rounds. The player should also be made aware that any subsequent ruling may be different from the Duration of Round Answer which was given.

### A. Queries Arising Before the Competition Begins

1. Officials should always ascertain why the player, opponent or third party is querying the club.
2. A positive ruling should only be given at this stage if the Official is absolutely certain he or she is correct. As a precautionary measure, always refer to the Equipment Rules, the Rules of Golf, and the Official Guide to the Rules of Golf before giving the ruling.
3. If the Official is not certain of the ruling, and time permits, advice should be sought from The R&A or USGA. First, it should be determined whether the club has ever been formally submitted for a decision.
4. If an R&A or USGA decision exists, and the Official is made aware of that decision in time, the player should be informed accordingly.
5. If there is no R&A or USGA decision on record, the Official should provide The R&A or USGA with a detailed description of the club. If time permits and appropriate facilities exist, an e-mailed or texted image should be sent. The R&A or USGA will then offer as much guidance as possible based on the information given – and in most cases, offer a recommended ruling.
6. The Official should make a ruling on the club based on the advice given by The R&A or USGA. If the club is clearly either ‘conforming’ or ‘non-conforming’, the Official should provide a ruling to that effect. However, if there is even a small amount of uncertainty, the Official should only offer a Duration of Competition or Duration of Round Answer.
7. If, due to the close proximity of a player’s starting time, the Official cannot reasonably seek advice, or is unable to contact The R&A or USGA, then he or she should advise the player not to make a stroke with the club for that round.
8. If later advice confirms that the club does conform and the player has already started his or her round without the club, then the player should be given a formal ruling as soon as possible. This would mean that the player could add the club to his or her bag during the round (provided the player had started with less than 14) or could make a stroke with the club in the next round. If later advice confirms that the club probably conforms and the player has already started his or her round without the club, then the player should be advised as soon as possible that he or she can make a stroke with the club for the duration of the competition in stroke play (Duration of Competition Answer) or for the duration of the round in match play (Duration of Round Answer). This would also mean that the player could add the club to his or her bag during that round (provided the player had started with less than 14).

9. Any player who ignores an Official's advice and makes a stroke with a doubtful club would be subject to penalty under Rule 4.1 of the Rules of Golf in the event of a subsequent non-conforming Duration of Competition, Duration of Round Answer, or formal ruling. This would apply whether the competition was closed or not.

### **B. Queries Arising During Stroke Play Competition**

1. If the club has already been used to make a stroke, Officials should only accept queries between rounds, or at the conclusion of play before the competition is closed.
2. The Official should ascertain why the player or third party is querying the club.
3. If the Official is absolutely certain of the correct decision, then the player should be informed (see A2 above).
4. If the Official is unsure of the ruling, the player should be advised that he or she will receive either a formal ruling or a Duration of Competition Answer before the close of the competition. The procedure is the same as for a query arising before the competition began (see A3 – A6 above).
5. If no Duration of Competition Answer is given and later advice confirms that the club does not conform, then the player should be penalized under Rule 4.1 of the Rules of Golf.

### **C. Queries Arising During Match Play Competition**

1. During a match play event the above procedure may need to be modified.
2. If the query arises between rounds, then it would be too late for a defeated opponent of the player with a suspect club to make a ruling request, but a query from him or her would be grounds for checking the club before the player starts his or her next round.
3. The procedure would be to consult with the player, opponent or third party and obtain all available information before making a determination. While the main procedures would be the same as for stroke play competitions (see A3 – A6 above), there may be more urgency in match play as it would be desirable to know whether the club is non-conforming before the player starts his or her next round, which might be the same day.
4. If a formal ruling is obtained or a Duration of Round Answer reached, the player should be told as soon as possible. If the decision is that the club does not conform, the official would warn the player that if he or she makes a stroke with the club in the next round, the player would be subject to penalty under Rule 4.1 of the Rules of Golf.



5. If a player makes a ruling request during a match that his or her opponent has made a stroke with a non-conforming club, the Official will have to make a ruling under even greater time constraints. Ideally, a ruling should be made before the match is finished. In that event, if there is no clear evidence that the club does not conform, the Official should almost always err towards ruling the club to conform. However, such a ruling would be considered to be a Duration of Round Answer and a more formal decision should be made prior to the next round.
6. Thereafter, if the opponent wins, the procedure is the same as for a query arising between rounds (see C3 and C4 above).

#### **D. Queries Arising After Competition Closed**

Once a competition has closed, there is plenty of time to contact The R&A or USGA to find out whether the club conforms or not and/or to submit the club. If it turns out that the club is non-conforming, the decision whether to disqualify the player or not depends on whether he or she knew the club was non-conforming (see Rule 20.2e(2)). This is a question of fact, but in determining the facts, the Committee may wish to consider other evidence as well as the player's own statement.

#### **Conclusion**

The vast majority of golf clubs conform to the Rules and, therefore, equipment conformance queries of this kind are rare. However, queries do arise from time to time and Officials need to know how to deal with them. It is important to remember that it is a player's responsibility to play with conforming clubs. He or she cannot shift this responsibility to the Official. For their part, Officials should respond to such queries with due consideration to all parties involved. Appropriate consultations should be made (i.e. referencing the Equipment Rules, the Rules of Golf, and the Clarifications on the Rules of Golf, contacting The R&A or USGA, etc.). If it is not possible to give a definitive ruling straight away, a Duration of Competition or Duration of Round Answer should be given (but see A7).

In giving Duration of Competition or Duration of Round Answers, Officials in doubt should err towards deeming clubs to conform. Penalizing a player for making a stroke with a club that later turns out to be conforming is a more serious error than allowing use of a club which later turns out to be non-conforming.

## Supplementary Paper B

### GUIDANCE ON HOW TO MEASURE GROOVES ON CLUB FACES FOR CONFORMANCE TO PRE-2010 RULES IN THE FIELD

#### Introduction

The following pages give guidance on how to measure grooves on club faces for width and separation, using the “Ink and Scratch” method, and depth. They concentrate solely on the Rules which apply to the grooves on iron and wood clubs manufactured prior to 1 January 2010, but, if necessary, the same procedures and equipment can be used to measure grooves on a putter face (see Rule 5f of the Equipment Rules).

For those Officials who have not carried out these measurements before, we recommend setting aside time, a day or more prior to the tournament, for groove checking if required, rather than doing it on the first day. It only takes a few minutes to measure the grooves on a club, but it is important not to be rushed. We also recommend practice-measuring on at least six club faces – preferably more – before doing it “in the field”.

A one-page summary of the procedure for measuring the width and separation of the grooves on iron and wood clubs is attached, which, in conjunction with the specially designed results sheet, may give sufficient instruction, once the user has gained some experience in measuring grooves. An abbreviated form of the test, appropriate for clubs which comfortably meet the groove specifications, is also outlined.

#### Groove Width and Separation

In order to carry out the “Ink and Scratch” method of measuring grooves, the following equipment is required:

1. A thick black marker pen
2. A carbide wedge ‘Marking Tool’ with Allen key (see Figure 2 below)
3. A magnifier
4. A steel ruler
5. An alcohol wipe (to clean the club face)

This equipment may be available from The R&A or USGA at a reasonable cost.

#### How to Ink and Mark the Grooves

1. Make sure that the club face and grooves are clean. Also check that the tungsten carbide “wedge” in the marking tool is properly square to the axis of the tool and securely fixed. If not, adjust with the Allen key provided.

- Use the marker pen to coat a 0.25 to 0.5 inch (5 to 10 mm) width of the edges of ten grooves (and the nearby part of the flat area between them), making sure that the ink gets down into the grooves. The inked pattern thus formed should lie in a line running from sole to top edge of the club face. For new clubs do this about 0.5 inches (10 mm) to one side of the centre of the face (See Figure 1 below). For used clubs do it near the toe, but not at the very end of the grooves (but see also Paragraph 13).

Fig. 1

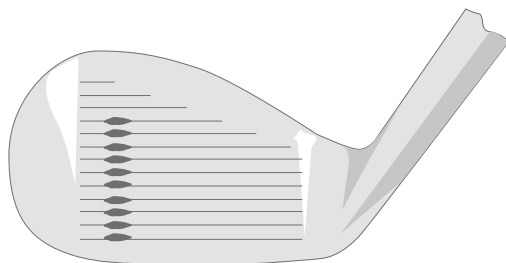

- When the ink is dry take the marking tool, hold it like a pencil at about  $45^\circ$  to the club face and insert the pointed corner of its tip into one of the blackened grooves. (See Figure 2 below) Using firm but not too heavy pressure, pull the tool along the groove for about 0.25" (5 mm). Two narrow bright lines of exposed metal should now be visible, one on each side of the groove denoting the position of the edges of the grooves. (See Figure 3).
- Do the same for all ten blackened grooves.

Fig. 2

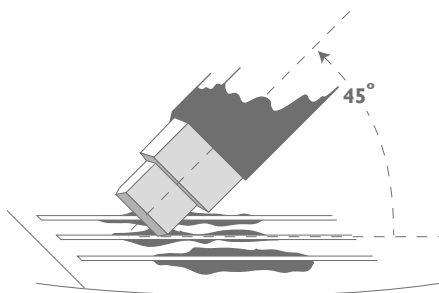
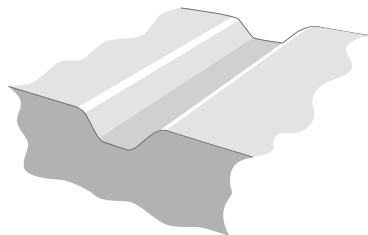

Fig. 3



### How to Use the Magnifier

- The magnifier comes with two scale glasses, one already fitted and the other in a separate holder. They are identical, except that scale markings are black on one and white on the other. On nearly all club faces the white scale will be easier to read.
- Rest the clubhead on a table or other surface, so that the club face is horizontal. You may find it helps to rest the club's shaft on your shoulder or on some raised object, in order to leave both hands free to adjust the magnifier.

Since good light is needed it is helpful, indoors, to place a reading lamp close to the clubhead, preferably shining along the direction of the grooves on the club face. Make sure you hold the magnifier in such a way that your fingers do not obscure the light.

- Place the magnifier on the club face and look through it. By turning the knurled ring on the eyepiece you should be able to bring into sharp focus both the scale and surface features on the club face. You should also be able to see clearly the bright edges you have scraped on the grooves against the black background.

Notice that the magnifier scale is in thousandths of an inch (or millimetres) and is marked at intervals of 0.005 inches (0.5 mm), except immediately to the right of the long vertical zero line, where the intervals are 0.008 inches (0.2 mm) or 0.004 inches (0.1 mm). You should use this latter part of the scale for the precise measurement of the groove width (See Figure 4).

Fig. 4

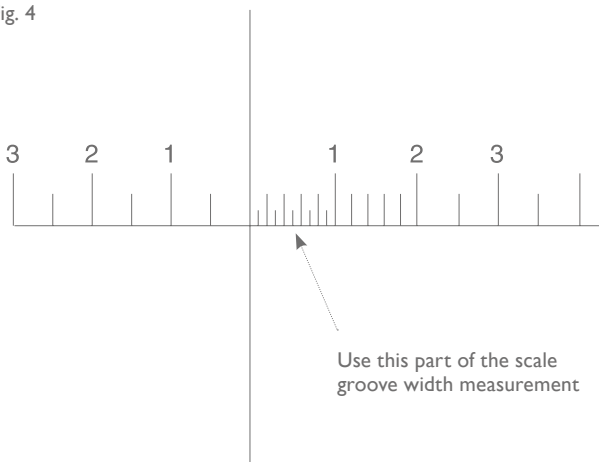

### Measuring the Grooves

- Use the magnifier to measure the width ( $W$ ) of ten grooves whose edges have been marked by the tool. This may be done by lining up the long vertical zero line on the magnifier scale along the left edge of each groove (i.e. along the middle of the bright line scratched by the tool) and reading off the position of the other edge on the portion of the magnifier scale which reads to 0.005 inches or 0.1 mm. For best results the scratched line should be about 0.005 inches or 0.1 mm wide, in which case each measurement can be made to the nearest 0.002 inches or 0.05 mm (e.g. 0.65 mm, 0.80 mm). If it is appreciably wider than 0.005 inches or 0.1 mm, then too much pressure has been applied in using the marking tool. In that case abandon that particular part of the groove and do a repeat “ink and scratch” a little to one side.

Record all ten groove widths. Often they will be the same, or differ by only 0.002 inches or 0.05 mm.

Calculate and record the average width,  $W_{av}$ ; note the largest measured width,  $W_{max}$ .

Note the second largest width, and the second smallest. Calculate the difference between them, and record it as  $W_{var}$  (“Width variation”).

- Determine the pitch of the grooves – the distance from a specific point on a groove to the same on the next groove, for example centre to centre, or left edge to left edge (See Figure 5).

Fig. 5

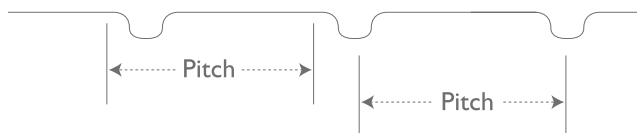

This measurement can be made either with the steel ruler or with the magnifier; but, in most cases, the steel ruler is the more convenient. Measure the left edge to left edge distance from groove 1 to groove 11 (or 2 to 12 etc), and divide this distance by 10 to arrive at the pitch,  $P$ . If a ten groove span is not available, then nine or eight will be satisfactory (but remember to divide by the appropriate number to find  $P$ ).

Alternatively, and this is the only option if a span of fewer than eight grooves is available, you can use the magnifier. Measure the distance from one edge of groove 1 to the corresponding edge of groove 5. The best way to do this is to position the long zero line of the magnifier scale on the left edge of groove 3 then read off the distances on either side of it to grooves 1 and 5 and add them together. You can, of course, use any two grooves spaced four apart (e.g. 3 and 7, or 6 and 10); indeed, it may be as well to check your first measurement by repeating the procedure with another such pair of grooves.

It is good enough to make this measurement to the nearest 0.005 inches or 0.1 mm. Then divide the measured span of four grooves by 4 to give the pitch,  $P$ .

Whichever method is used, the object is to get the best possible measure of the average groove pitch ( $P$ ).

At this stage it may be worth checking your average by measuring the pitch from one groove to the next one, e.g. grooves 1 to 2, or 5 to 6. If these measurements differ from the average by more than 0.005 or 0.1 mm, then either you calculated the average incorrectly (check it), or the grooves are unevenly spaced. In the latter event you must measure the grooves differently (see Section 14).

### Errors and Uncertainty in Measuring

9. With a little practice you can measure the groove width with an uncertainty as little as 0.002 inches or 0.05 mm (i.e. it could be wrong by at most 0.02 inches or 0.05 mm). In tests for conformity the manufacturer is given the benefit of all of that uncertainty.

This is done by subtracting 0.02 inches or 0.05 mm from all the measurements noted in Section 7, namely  $W_{av}$ ,  $W_{max}$  and  $W_{var}$ , to give “adjusted” values of these quantities. We call them  $AW_{av}$ ,  $AW_{max}$  and  $AW_{var}$ ; it is these which are used in all tests for conformity.

**10. How to Determine whether Clubs Available Prior to 1 January 2010 Conform to Pre-2010 Groove Requirements (applicable to golf played where the Groove and Punch Mark Condition is not in use)**

**(i) Groove Width**

If the average width of the measured groove widths exceed 0.035" (0.889 mm) then the club is non-conforming.

If any single measured groove width exceeds 0.039" (1.0 mm) then the club is non-conforming.

**(ii) Groove Separation**

The pitch of the grooves, as described in Section 8, must not be less than four times the width. Thus, the grooves do not conform if  $P/AW_{av}$  is less than 4.0.

$P - AW_{av}$  must not be less than 0.075" or 1.9 mm.

**(iii) Groove Consistency**

The difference in width between the second widest and the second narrowest groove must not exceed 0.004" or 0.1 mm. The grooves do not conform if  $AW_{var}$  is greater than 0.004" or 0.1 mm.

11. It is recognized that groove measurements made, as these are, at one point along the length of the grooves, are sensitive to small manufacturing errors. Therefore, if a club fails on one of the above criteria, it should not immediately be declared non-conforming; but the whole measuring procedure should be repeated at a slightly different part of the face (say 0.394" or 10 mm to the other side of the centre of a club face from the first set). For a club to be declared non-conforming, it must fail to meet the same specification on both sets of measurements. In the case of a single overwidth groove ( $AW_{max}$ ), the same groove must be overwidth on both measurements.

### Irregular or Unusual Grooves

12. For grooves with markedly varying separation (See Figure 6 below), the above procedures need modification, though the same measuring technique applies. In general, the concept of *average* groove pitch has to be abandoned and groove pitch (or separation) taken for individual pairs of adjacent grooves. In the sample illustrated, the club face would need to be divided into two or even three separation regions.

Difficult cases should be submitted to the The R&A or USGA for a ruling.

Fig. 6

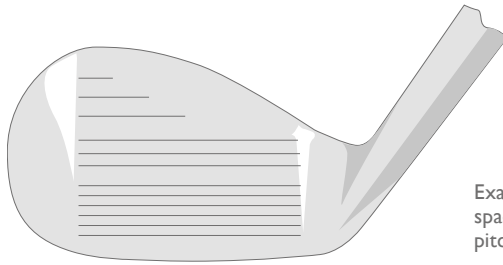

Example of non-uniform spacing where the 'average' pitch is meaningless

13. For used clubs with worn grooves the width measurements must be made on grooves which are not worn. These can nearly always be found near the toe of the club, or high on the face. Avoid the extreme end of the grooves since the width sometimes varies there. If it is impossible to find ten unworn grooves, measure as many as possible and make the necessary modifications to the calculation of average width.

If the grooves on a used club have been deliberately altered by filing or the use of a groove scoring tool, then the club should be treated as though it were new and the grooves measured near the centre of the face.

14. Very occasionally grooves will be found which are either very shallow, or have sides which make an angle of less than  $30^\circ$  to the horizontal. In these circumstances the marking tool will not work properly and the club should be submitted to The R&A or USGA for a ruling, although it may be possible to give an "on the spot" conforming ruling if the grooves clearly conform.



## SUMMARY OF GROOVE MEASURING PROCEDURE

(The bracketed numbers refer to the corresponding paragraphs in Supplementary Paper B – “Guidance on the Measurement of Grooves on Club Faces”)

1. Clean club face [1]; ink the edges of ten grooves in a 5mm wide band. [2]
2. Check marking tool [1]; use it as described in full instructions [3] to scrape the edges of the inked grooves.
3. Use the magnifier to measure the width of all ten grooves, and record on the results sheet. [4, 5, 6, 7]
4. Calculate and record on the results sheet the average width, the greatest width and the width variation. [7]
5. Calculate and record the adjusted widths which allow for the uncertainties of measurement. [9]
6. Use the ruler to measure a span of ten grooves (e.g. from groove 1 to groove 11 (not 10), or 2 to 12). [8]  
{OR, if preferred, use the magnifier to measure a four groove span. [8]}
7. Calculate and record the average groove-to-groove pitch. [8]
8. Calculate and record the pitch to width ratio, remembering to use the adjusted width; also calculate the separation (pitch minus adjusted width).
9. Using quantities calculated in 5 and 8 above, answer the questions near the foot of the results sheet to determine whether the grooves conform. [10, 11] Manufacturers are advised to use actual widths in these calculations. [9]
10. Follow the steps on the results sheet to reach a decision on the club, if necessary repeating the measurement. [11]

\* \* \*

NB. Consult the full instructions for grooves with inconsistent spacing, or other unusual features [12, 13, 14].

## ABBREVIATED PROCEDURE FOR GROOVE MEASUREMENTS

It may be quite acceptable, for an experienced user of the measuring equipment, to abbreviate the measuring procedure on clubs whose grooves clearly lie well within the specified dimensions.

First, inspect the club face by eye, and check whether the grooves are:

- a) unevenly spaced
- b) of unequal width
- c) unusually wide
- d) unusually close together

If any of these conditions apply, then the full measurement must be carried out.

If none of these conditions apply, then the following abbreviated procedure may save some time and effort without affecting the outcome:

Ink and mark three grooves, and measure their width with the magnifier. Take the greatest of the three measured widths and add 0.002" or 0.05 mm to it. Call this  $W(+)$ .

*(For example, if the three widths were measured as 0.030" or 0.75 mm, 0.033" or 0.80 mm and 0.030" or 0.75 mm, then  $W(+)$  would be 0.033" or 0.85 mm).*

Then measure the pitch,  $P$ , with the steel ruler as described in the full procedure.

Then check:

Is  $W(+)$  less than 0.035" or 0.9 mm?

Is  $W(+)$  less than  $P/4$ ?

Is  $P - W(+)$  greater than 0.075" or 1.9 mm?

If all the answers are YES (and you have carried out the initial visual check), the club is certain to meet the requirements of the full tests; and it may be deemed to conform without further testing.

If any of the answers are NO, the full measurement must be carried out.

**IF YOU HAVE ANY DOUBT, CARRY OUT THE FULL MEASUREMENT.**

## GROOVE MEASUREMENT ON \_\_\_\_\_ (club name)

DATE: \_\_\_\_\_ MEASURED BY: \_\_\_\_\_

## 1. WIDTH OF INDIVIDUAL GROOVES

Groove 1 =	in or mm	Groove 6 =	in or mm
Groove 2 =	in or mm	Groove 7 =	in or mm
Groove 3 =	in or mm	Groove 8 =	in or mm
Groove 4 =	in or mm	Groove 9 =	in or mm
Groove 5 =	in or mm	Groove 10 =	in or mm

Average width ( $W_{av}$ ) = \_\_\_\_\_ in or mm    Greatest width ( $W_{max}$ ) = \_\_\_\_\_ in or mmSecond greatest minus second smallest width ( $W_{var}$ ) = \_\_\_\_\_ in or mm

To give benefit of measuring error to the club, subtract 0.002" or 0.05mm (the maximum error) from these widths to give the corresponding "adjusted widths":

$AW_{av}$ = _____ in or mm	$AW_{max}$ = _____ in or mm	$AW_{var}$ = _____ in or mm
----------------------------	-----------------------------	-----------------------------

THESE ARE THE WIDTHS USED IN ALL CALCULATIONS HEREAFTER

## 2. PITCH OF GROOVES

Span of ten grooves (measured by steel ruler) = \_\_\_\_\_ in or mm

Therefore pitch,  $P$  = \_\_\_\_\_ /10 = \_\_\_\_\_ in or mm

{ALTERNATIVELY: Span of four grooves (measured by magnifier) = \_\_\_\_\_ in or mm

Therefore pitch,  $P$  = \_\_\_\_\_ /4 = \_\_\_\_\_ in or mm

Note pitch measurement in left hand box below. Calculate and enter the other quantities.

$P$ = _____ in or mm	$P/AW_{av}$ = _____	$P - AW_{av}$ = _____ in or mm
----------------------	---------------------	--------------------------------

## 3. TEST FOR CONFORMANCE

Is $AW_{av} > 0.035$ " or 0.9 mm?	YES/NO
Is $AW_{max} > 0.004$ " or 1.0 mm?	YES/NO
Is $P/AW_{av} < 4.0$ ?	YES/NO
Is $P - AW_{av} < 0.075$ " or 1.9 mm?	YES/NO
Is $AW_{var} > 0.004$ " or 0.1 mm?	YES/NO

IF ALL ANSWERS ARE 'NO', OR IF 'YES' ANSWERS ARISE ONLY WHERE THE FIRST MEASUREMENT GAVE 'NO', GROOVES ON CLUB CONFORM. No further measurements are needed.

IF ANY 'YES' ANSWERS ARE REPEATS OF THOSE IN FIRST MEASUREMENT, THE GROOVES DO NOT CONFORM.

Circle the appropriate word: **CONFORMING**    **NON-CONFORMING**

REPEAT GROOVE MEASUREMENT ON (club name)

DATE: MEASURED BY:

1. WIDTH OF INDIVIDUAL GROOVES

Groove 1 =	in or mm	Groove 6 =	in or mm
Groove 2 =	in or mm	Groove 7 =	in or mm
Groove 3 =	in or mm	Groove 8 =	in or mm
Groove 4 =	in or mm	Groove 9 =	in or mm
Groove 5 =	in or mm	Groove 10 =	in or mm

Average width ( $W_{av}$ ) = in or mm    Greatest width ( $W_{max}$ ) = in or mm

Second greatest minus second smallest width ( $W_{var}$ ) = mm

To give benefit of measuring error to the club, subtract 0.002” or 0.05mm (the maximum error) from these widths to give the corresponding “adjusted widths”:

$AW_{av}$ = in or mm	$AW_{max}$ = in or mm	$AW_{var}$ = in or mm
----------------------	-----------------------	-----------------------

THESE ARE THE WIDTHS USED IN ALL CALCULATIONS HEREAFTER

2. PITCH OF GROOVES

Span of ten grooves (measured by steel ruler) = in or mm

Therefore pitch,  $P$  = /10 = in or mm

{ALTERNATIVELY: Span of four grooves (measured by magnifier) = in or mm

Therefore pitch,  $P$  = /4 = in or mm

Note pitch measurement in left hand box below. Calculate and enter the other quantities.

$P$ = in or mm	$P/AW_{av}$ =	$P - AW_{av}$ = in or mm
----------------	---------------	--------------------------

3. TEST FOR CONFORMANCE

Is $AW_{av} > 0.035$ ” or 0.9 mm?	YES/NO
Is $AW_{max} > 0.004$ ” or 1.0 mm?	YES/NO
Is $P/AW_{av} < 4.0$ ?	YES/NO
Is $P - AW_{av} < 0.075$ ” or 1.9 mm?	YES/NO
Is $AW_{var} > 0.004$ ” or 0.1 mm?	YES/NO

IF ALL ANSWERS ARE ‘NO’, OR IF ‘YES’ ANSWERS ARISE ONLY WHERE THE FIRST MEASUREMENT GAVE ‘NO’, GROOVES ON CLUB CONFORM. No further measurements are needed.

IF ANY ‘YES’ ANSWERS ARE REPEATS OF THOSE IN FIRST MEASUREMENT, THE GROOVES DO NOT CONFORM.

Circle the appropriate word: **CONFORMING**    **NON-CONFORMING**

### Groove Depth

In order to help Officials rule on the groove depth “in the field”, a simple gauge has been developed which is available from The R&A or USGA at a reasonable cost.

The gauge consists of a small circular disc which has a raised, thin ridge running across the diameter. This ridge measures exactly 0.022 inches (0.559 mm) in depth, which offers a small tolerance suitable for measurements carried out “in the field”.

### Method of Use

In order to judge the depth of a groove on a club, the disc should be placed onto the face with the ridge running along the inside of the groove. The user should then apply pressure to the disc, on both sides of the ridge, to see if the disc will rock from side to side.

If the disc does noticeably rock, then the groove cannot be too deep. It means that the depth of the ridge is greater than the depth of the groove.

If, on the other hand, the disc lies flush with the face and cannot be rocked, it means that the groove is likely to be too deep.

In both instances above, the gauge should be used on at least six grooves within the “impact area” of the face (or near the toe for club faces which are quite worn).

If 50% or more of the grooves tested appear to be too deep when using this gauge, the club should not be carried.

### Punch Marks

Punch marks are almost always circular in shape and, therefore, the area of the punch mark can be determined using the calculation  $\pi r^2$  (where  $\pi \approx 3.142$ ). The radius of the punch mark can be measured using a magnifier as can the separation of two punch marks – measured centre to centre. The depth measurement would require the use of a depth probe. While the depth of a punch mark is limited to 0.040 inches (1.02 mm) within the Rules, it is highly unlikely that this measurement would ever be queried “in the field”.

## Definition of “Impact Area” – for clubs manufactured prior to 1 January 2010

For iron clubs, the “impact area” is deemed to be that part of the face which lies within 0.79 inches (20 mm) either side of the vertical centre line of the face, but excluding strips 0.25 inches (6.25 mm) wide from the top and bottom edges.

For metal wood clubs, the shape of the impact area is generally based on the traditional insets used in persimmon type wood clubs. Figure 7 illustrates the shape and dimensions of this area.

Figure 7 – Impact Area for Metal Woods (for pre-2010 Clubs)

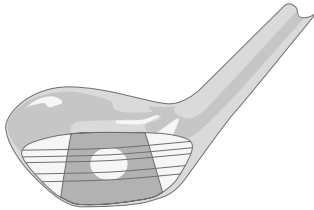

(a) Guideline is based in style of the traditional inset used in persimmon wood clubs.

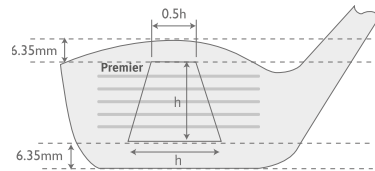

(b) Metal wood head showing size and shape of impact area. The word “Premier” does not encroach the area, therefore the club is conforming.

The height ( $h$ ) of the trapezium is used to fix the horizontal dimensions namely “ $1/2h$ ” at the top and “ $h$ ” at the base. This ensures that all impact areas are similar.

## Supplementary Paper C

### 2010 CLUB FACE MARKINGS

#### **New Specifications and Interpretations**

From 1 January 2010, the Rules on club face markings include the following three additional specifications for clubs other than driving clubs and putters:

- The total cross-sectional area of a groove divided by the groove pitch (width plus separation) will be limited to 0.0030 square inches per inch (0.0762 mm<sup>2</sup>/mm);
- Groove edge sharpness will be required to be substantially in the form of a round having an effective minimum radius of 0.010 inches (0.254 mm). This limit will only apply to clubs with lofts of 25 degrees and above.
- Grooves will be required to be plain.

As previously intimated (see Section 5c), these new specifications only affect new models of clubs manufactured on or after 1 January 2010 and competitions where the Groove and Punch Mark Condition is in use.

#### **Interpretation of a Plain Groove**

- The groove starts where there is a significant departure from the plane of the face and this is joined to the side (or wall) of the groove via the edge. The side (or wall) continues to the base of the groove.
- The sides (or walls) of the groove must be substantially plain and planar. This disallows features such as bends, indentations in or protrusions from the wall.
- The base of the groove must also be substantially plain and join the two opposing sides (or walls) of the groove using a concave shape or a plane.
- Groove edges must be a convex curve and must not include serrations, gear teeth or other similar features.
- For clubs with lofts less than 25 degrees, where it is difficult to determine whether a groove violates either the edge requirement or the plain wall requirement, the groove will be deemed to meet the plain wall requirement.

Based on all of the above, the following images are illustrative examples of permissible groove geometries:

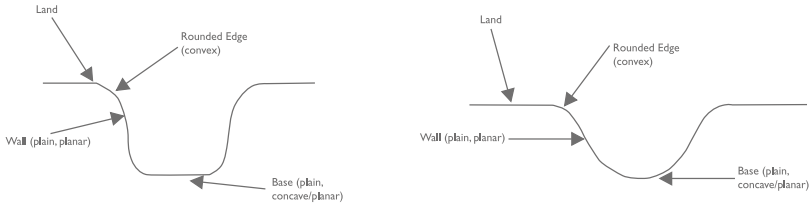

### Determining the Status of Markings in the Impact Area Against 2010 Specifications

Full details of the procedure for measuring club face markings and determining their status against the 2010 specifications can be found on The R&A's website. However, a summary is as follows:

The following algorithm will be used to determine the conformance status of clubs to the new Rules on impact area markings from 1 January 2010, regardless of what method has been used to obtain the measurements. Within the following procedure, the inherent difficulty of manufacturing grooves has been taken into consideration. However, it should be stressed that clubs must be designed and manufactured with the intent of conforming to the Rules.

Note that, for all dimensional limitations described below, each measurement will be based on a confidence level of at least 95% confidence as determined by standard Gauge R&R procedures. All measurements will include appropriate outlier controls to ensure that rulings are not based on spurious or anomalous data. Improvements to measurement techniques and consequently the associated measurement tolerances may be introduced at any time.

#### (i) Groove Width

- If 50% or more of the measured groove widths exceed 0.035" (0.889 mm) then the club is non-conforming.
- If any single measured groove width exceeds 0.037" (0.940 mm) then the club is non-conforming.



**(ii) Groove Depth**

- If 50% or more of the measured groove depths exceed 0.020" (0.508 mm) then the club is non-conforming.
- If any single measured groove depth exceeds 0.022" (0.559 mm) then the club is non-conforming.

**(iii) Groove Separation**

- If 50% or more of the measured groove separations are less than three times the maximum adjacent measured groove width then the club is non-conforming.
- If any single measured groove separation is less than three times the maximum adjacent measured groove width minus 0.008" (0.203 mm) then the club is non-conforming.
- If 50% or more of the measured groove separations are less than 0.075" (1.905 mm) then the club is non-conforming.
- If any single measured groove separation is less than 0.073" (1.854 mm) then the club is non-conforming.

**(iv) Groove Consistency**

Grooves must be designed and manufactured with the intent of being symmetric, parallel and consistent throughout the impact area. Consistency is interpreted to be:

- The range of measured groove widths cannot exceed 0.010" (0.254 mm).
- The range of measured groove depths cannot exceed 0.010" (0.254 mm).

Inconsistencies in the groove width, spacing or cross-section for the purpose of influencing the movement of the ball are not permitted, regardless of whether the above requirements are satisfied.

**(v) Area over Width Plus Separation**

- If 50% or more of the measured values of  $A/(W+S)$  are greater than 0.0030 square inches per inch (0.0762 mm<sup>2</sup>/mm) then the club is non-conforming.
- If the measured value of  $A/(W+S)$  value for any single groove is greater than 0.0032 square inches per inch (0.0813 mm<sup>2</sup>/mm) then the club is non-conforming.

**(vi) Groove Edge Radius**

Rounding of groove edges shall be in the form of a radius having an **effective** radius not less than 0.010" (0.254 mm) as determined by the two circles method, nor greater than 0.020" (0.508 mm). The following two criteria are used for determining conformance:

- If 50% or more of the upper groove edges or 50% or more of the lower groove edges fail the two circles method subject to a 10 degree angular allowance, then the club is non-conforming.
- If any single groove edge protrudes more than 0.0003" (0.0076 mm) outside the outer circle, then the club is non-conforming.

**(vii) Punch Marks**

- If 50% or more of the punch mark edges fail the two circles method subject to a 10 degree angular allowance, then the club is non-conforming.
- If any single punch mark edge protrudes more than 0.0003" (0.0076 mm) outside the outer circle, then the club is non-conforming.

NB: As a result of the new Rule limiting the  $A/(W+S)$  of grooves, from 1 January 2010 the volume of punch marks in the impact area must not exceed the allowable value for an equivalent groove (that is, 0.0030 in<sup>3</sup> per square inch (0.0762 mm<sup>3</sup>/mm<sup>2</sup>) of impact area covered by punch marks).



The R&A and USGA evaluate golf balls, golf clubs and other equipment for conformance to the Equipment Rules at their Research and Test Centers in Kingsbarns, Scotland and Liberty Corner, New Jersey, USA. For more information on the Equipment Rules and the Rules of Golf, please contact The R&A or USGA.



**R&A**

**USGA**